

MPE PART EJECTOR MST PART POSITIONER

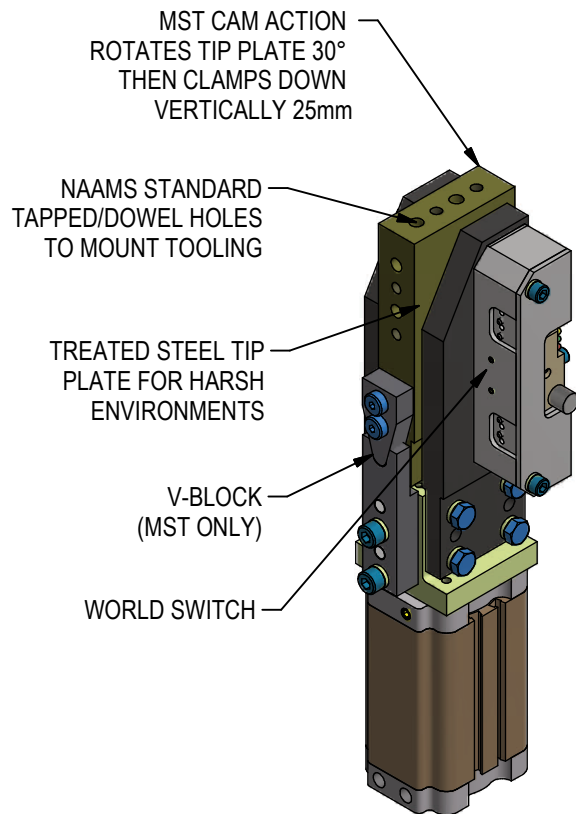
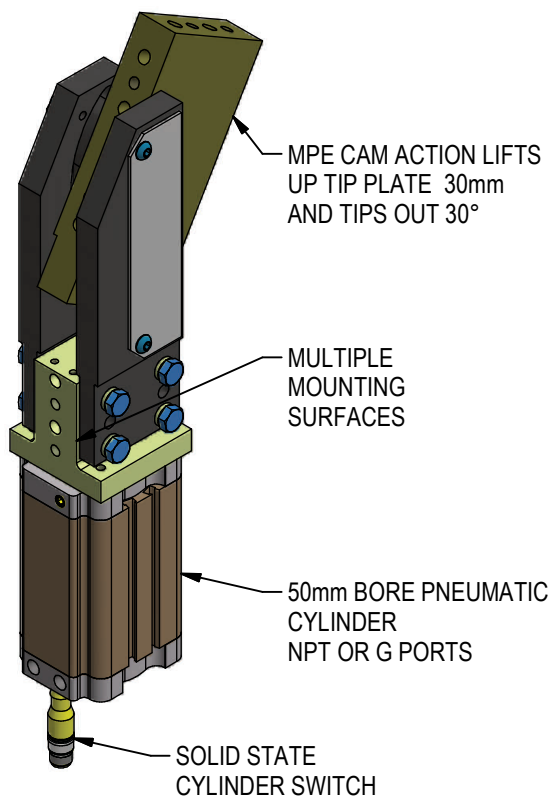

MPE

ONE ACTUATOR TO LIFT AND TIP TO EJECT

U.S. Patent 6918280 B2

MST

ONE ACTUATOR TO POSITION AND CLAMP

V-BLOCK ASSURES REPEATABILITY

RELEASED 1/20/21

ORDERING INFORMATION

NOTE: ALL BOXES MUST BE FILLED IN FOR A COMPLETE PART NUMBER

MINIMUM 2-SECOND CYCLE TIME FOR ONE DIRECTION

M	P	E	0	3	0	A			0	A				0	0	0
---	---	---	---	---	---	---	--	--	---	---	--	--	--	---	---	---

Series _____

Actuator _____

- 30 50mm Bore with NPT Ports
- 31 50mm Bore with G Ports

Switch Options - See Sheet 5 _____

World Switch Position _____

- 1 No World Switch (when selecting Solid State Cylinder Switch)
- 2 Switch @ Position 2
- 4 Switch @ Position 4

Port Position _____

- A Port @ Position 1
- B Port @ Position 2
- C Port @ Position 3
- D Port @ Position 4

M	S	T	0	3	0	A			0					0	0	0
---	---	---	---	---	---	---	--	--	---	--	--	--	--	---	---	---

Series _____

Actuator _____

- 30 50mm Bore with NPT Ports
- 31 50mm Bore with G Ports

V-Block Mount (on MST ONLY) _____

- A Shown below
- B V-Block mounted on opposite side of MST

Switch Options - See Sheet 5 _____

World Switch Position _____

- 1 No World Switch (when selecting Solid State Cylinder Switch)
- 2 Switch @ Position 2
- 4 Switch @ Position 4

Port Position _____

- A Port @ Position 1
- B Port @ Position 2
- C Port @ Position 3
- D Port @ Position 4

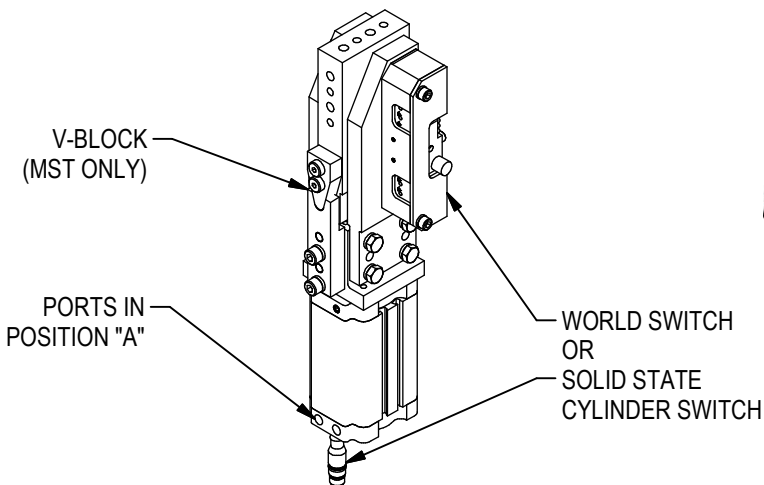

UNIT WEIGHTS	
UNIT	WEIGHT**
MPE	16.5 LBS
MST	17.4 LBS

**WEIGHTS SHOW ARE APPROXIMATE AND VARY WITH OPTIONS

(DO NOT SCALE DRAWING)

ENGINEERED PRODUCTS

800-229-0890 www.welkerproducts.com

MPE GENERAL DIMENSIONS

MINIMUM 2-SECOND CYCLE TIME FOR ONE DIRECTION

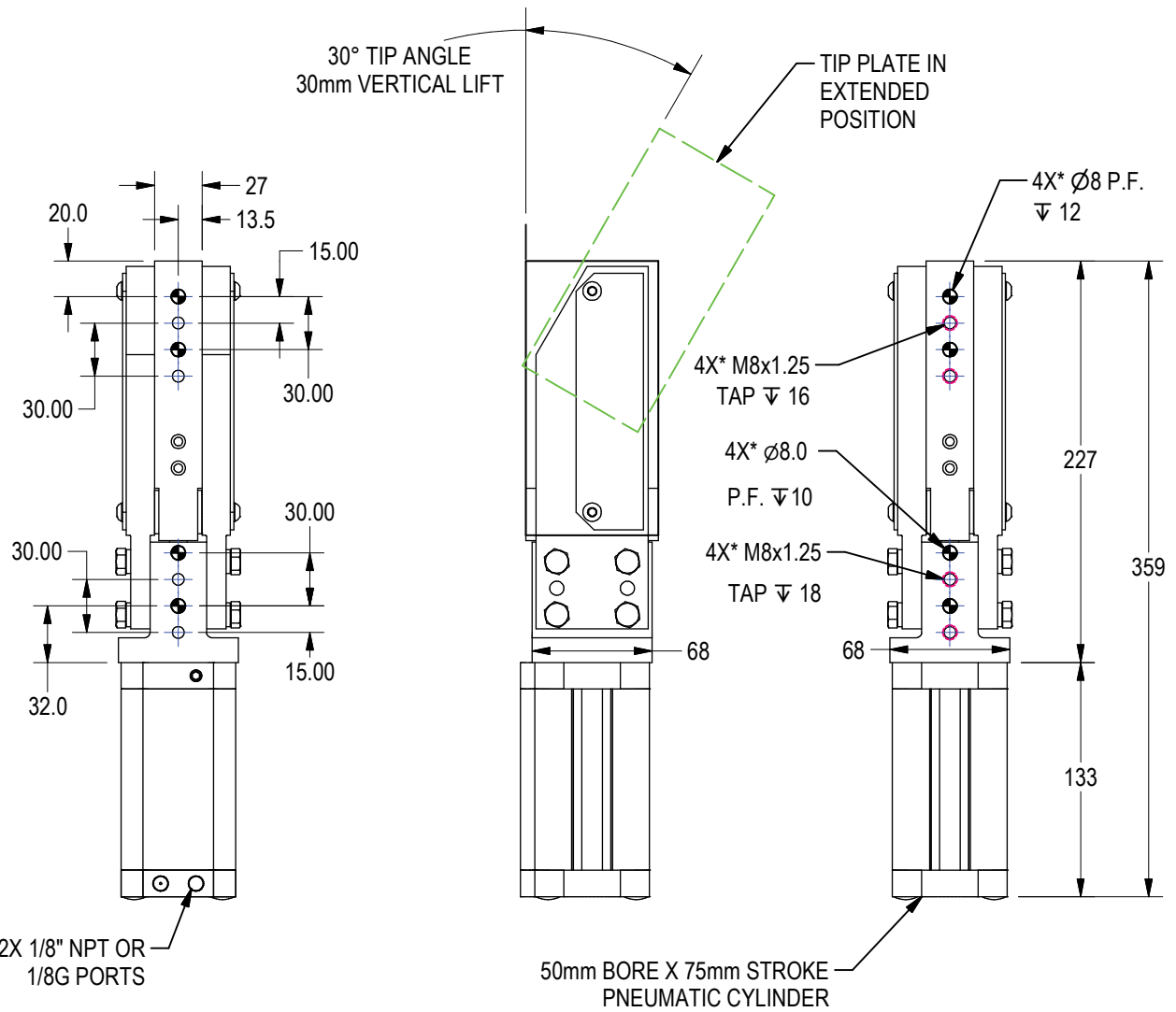
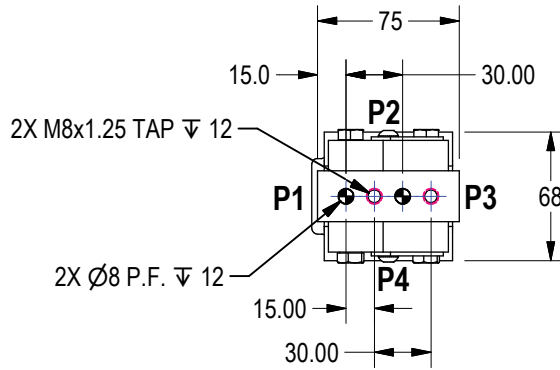

2X 1/8" NPT OR 1/8G PORTS

50mm BORE X 75mm STROKE PNEUMATIC CYLINDER

100 in lbf MAX TORQUE



UNIT WEIGHT: 17 LBS.
(VARIES WITH OPTIONS)

* 2X NEARSIDE
2X FARSIDE

SHEET 3

(DO NOT SCALE DRAWING)

WELKER
ENGINEERED PRODUCTS
800-229-0890 www.welkerproducts.com

MST GENERAL DIMENSIONS

MINIMUM 2-SECOND CYCLE TIME FOR ONE DIRECTION

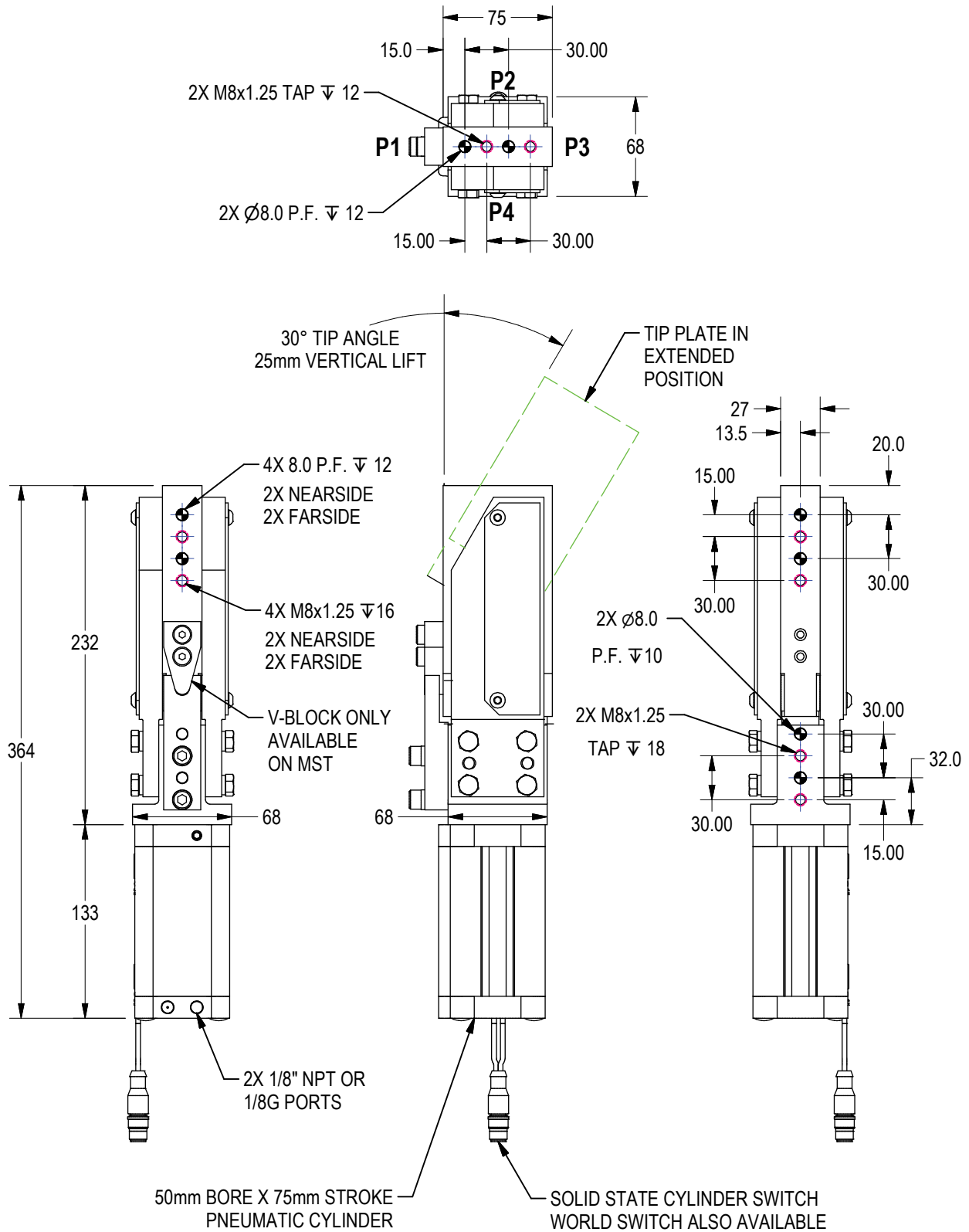

100 in lbf MAX TORQUE

(DO NOT SCALE DRAWING)



UNIT WEIGHT: 17.4 LBS
(VARIES WITH OPTIONS)

SHEET 4

WELKER
ENGINEERED PRODUCTS
800-229-0890 www.welkerproducts.com

SWITCH OPTIONS

M
S
T
0
3
0
A
3
0
0
A

A
0
0
0

Switch Options

- L3 Solid State Cylinder Switch - see chart below
- JE World Switch - see chart below

World Switch Position

- 1 No World Switch (when selecting Cylinder Switch)
- 2 Switch @ Position 2
- 4 Switch @ Position 4

	Order Number SO1 (E)XTEND or SO1 (R)ETRACT	Part Number	Manufacturer	Description
World Switches	99	Switch Ready		All switches are Quick Disconnect Customer Supplied Switch. Prepared for switches below :
	AE or AR	NI2-Q6.5-AP6-0.1-FS 4.4X3/S304	Turck	4-Wire, 4-Pin, DC M12 X 1 (PNP)
	BE or BR	NI2-Q6.5-ADZ32-0.1-FSB 5.4X4/S304	Turck	4-Wire, 5-Pin, AC/DC 1/2-20 (N.O.)
	CE or CR	NI2-Q6.5-AN6-0.1-FS 4.4X3/S304	Turck	4-Wire, 4-Pin, DC M12 X 1 (NPN)
	DE or DR	NBN2-F581-100S6-E8-V1	Pepperl & Fuchs	4-Wire, 4-Pin, DC M12 X 1 (PNP)
	EE or ER	BES-Z02KR2-PSC20F-P100-S04-V	Balluff	3-Wire, 4-Pin, DC M12 X 1 (PNP)
	JE or JR	IN5374	Efector	3-Wire, 4-Pin, DC M12 X 1 (PNP)
	ZE or ZR	WWS001A	Welker	4-Wire, 4-Pin, DC M12 X 1 (PNP)
Cylinder Switches	L3	SWITCH L3 ~ Weld field immune*, comparable to World Switches	Welker	4-Wire, 4-Pin, DC M12 X 1 (PNP)
	L5	MK5113 (single sensor switch: 2 switches are installed per cylinder)	if m Efector	3-Wire, 4-Pin, DC M12 X 1 (NPN)

Standard Switch Option - All other options may affect price and delivery

*Note that some mid and low frequency DC resistance applications (i.e. aluminum resistance welding applications) may cause a fault. In these applications, it is recommended that the sensor be ignored/bypassed during the welding cycle.

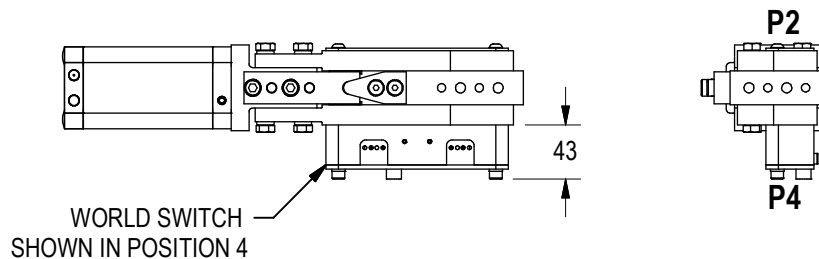

MINIMUM 2-SECOND CYCLE TIME FOR ONE DIRECTION

(DO NOT SCALE DRAWING)

ENGINEERED PRODUCTS

800-229-0890 www.welkerproducts.com

MPE PART EJECTOR & MST PART POSITIONER APPLICATION DATA

VERTICAL APPLICATIONS: MPE & MST

NOTE: CENTER OF GRAVITY AND PART CONTACT TOOLING MUST BE WITHIN DESIGNATED ZONE MAXIMUMS.

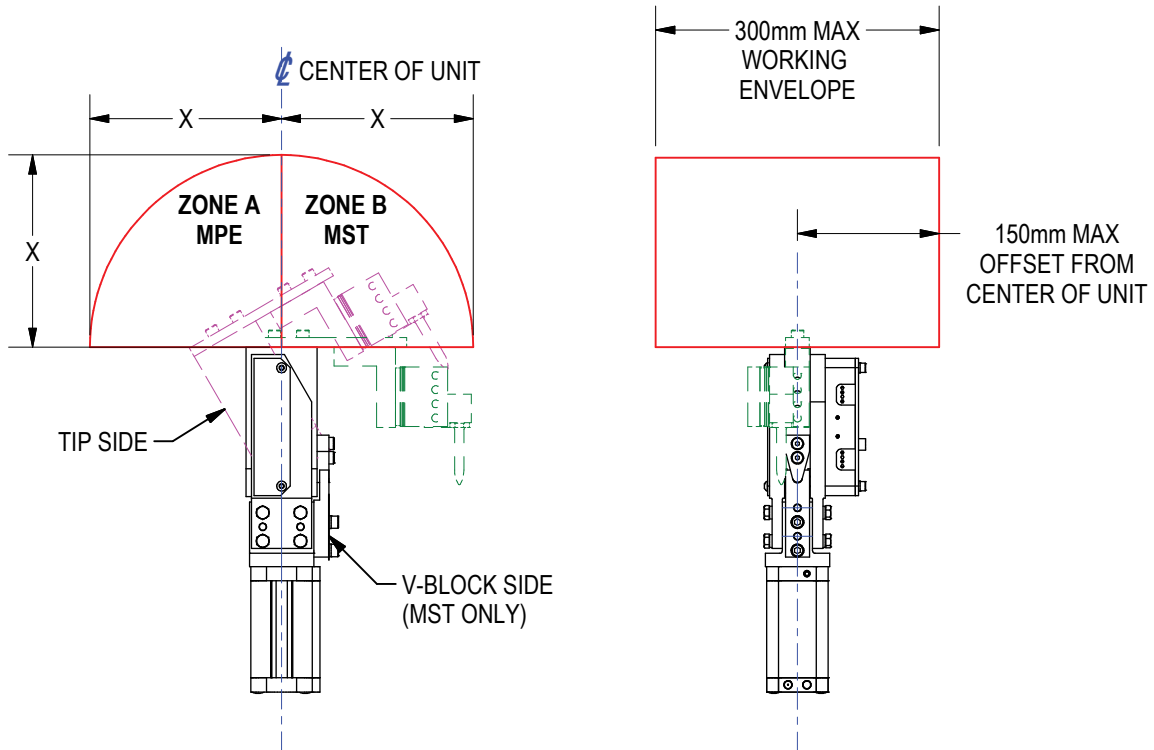

MINIMUM 2-SECOND CYCLE TIME FOR ONE DIRECTION

ZONE	DIM X	MAX LOAD
A	150mm (6")	15 LBS @ 60 PSI
	150mm (6")	15 LBS @ 80 PSI
	200mm (8") MAX	15 LBS @ 80 PSI
B	200mm (8")	25 LBS @ 60 PSI
	200mm (8")	30 LBS @ 80 PSI
C	150mm (6")	15 LBS @ 60 PSI
	200mm (8") MAX	10 LBS @ 80 PSI

HORIZONTAL APPLICATIONS: MST ONLY

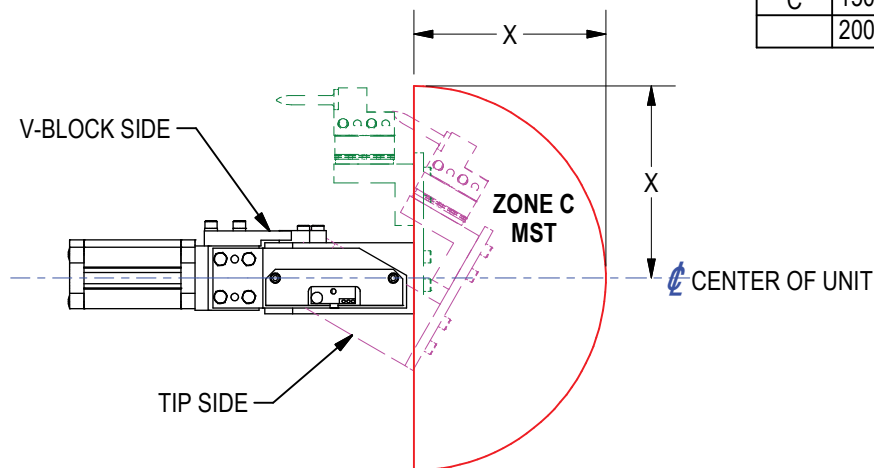

(DO NOT SCALE DRAWING)

WELKER
ENGINEERED PRODUCTS
800-229-0890 www.welkerproducts.com

MPE PART EJECTOR & MST PART POSITIONER: REQUIRED CRITERIA FOR APPLICATION APPROVAL

APPLICATION DATA MUST BE SUBMITTED FOR WELKER APPROVAL WITH THE FOLLOWING CRITERIA FOR ALL PART EJECTOR AND PART POSITIONER APPLICATIONS. PLEASE ATTACH THIS WORKSHEET TO YOUR BUY OFF AND INCLUDE A MINIMUM OF TWO SCREEN SHOTS OF YOUR APPLICATION WITH UNIT TIP PLATE IN EXTENDED POSITION.

FLOW CONTROLS ARE REQUIRED FOR ALL APPLICATIONS.

REF	DESCRIPTION	VALUE
	WELKER UNIT PART NUMBER	
	WEIGHT/MASS OF LOAD (TOOLING PLUS PARTS)	lbf
C	DISTANCE FROM PIVOT POINT TO LOAD CENTER OF GRAVITY	mm
D	DISTANCE FROM PIVOT POINT TO LOAD CENTER OF GRAVITY	mm
E	DISTANCE FROM CENTER OF UNIT TO LOAD CENTER OF GRAVITY	mm
F	ORIENTATION OF UNIT TO FLOOR	°

PLEASE SUBMIT VIEWS BELOW FOR APPROVAL

LOAD MUST BE WITHIN LIMITS SPECIFIED ON APPLICATION DATA SHEET

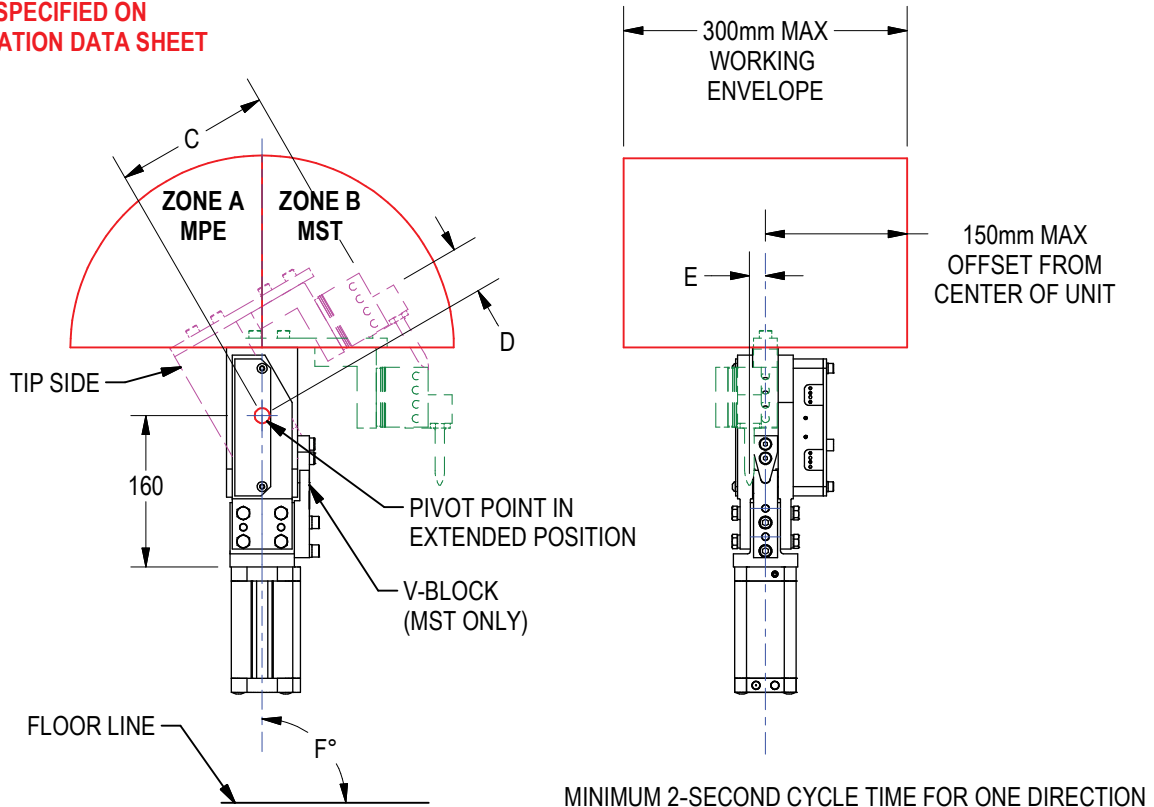

WELKER APPROVAL			
SUBMITTED BY		DATE	
PHONE NUMBER(S)		EMAIL	
COMPANY NAME		PROGRAM	
WELKER APPROVAL BY		DATE	

ACTUATOR	EXTEND TORQUE	RETRACT TORQUE
50mm BORE CYLINDER	100in-lbf	

(DO NOT SCALE DRAWING)

