

## MAINTENANCE MANUAL EXPANDING LOCATING PIN

NOTE: ALL WELKER EXPANDING PINS ARE CUSTOM DESIGNED PER APPLICATION  
STYLES SHOWN ARE EXAMPLES ONLY

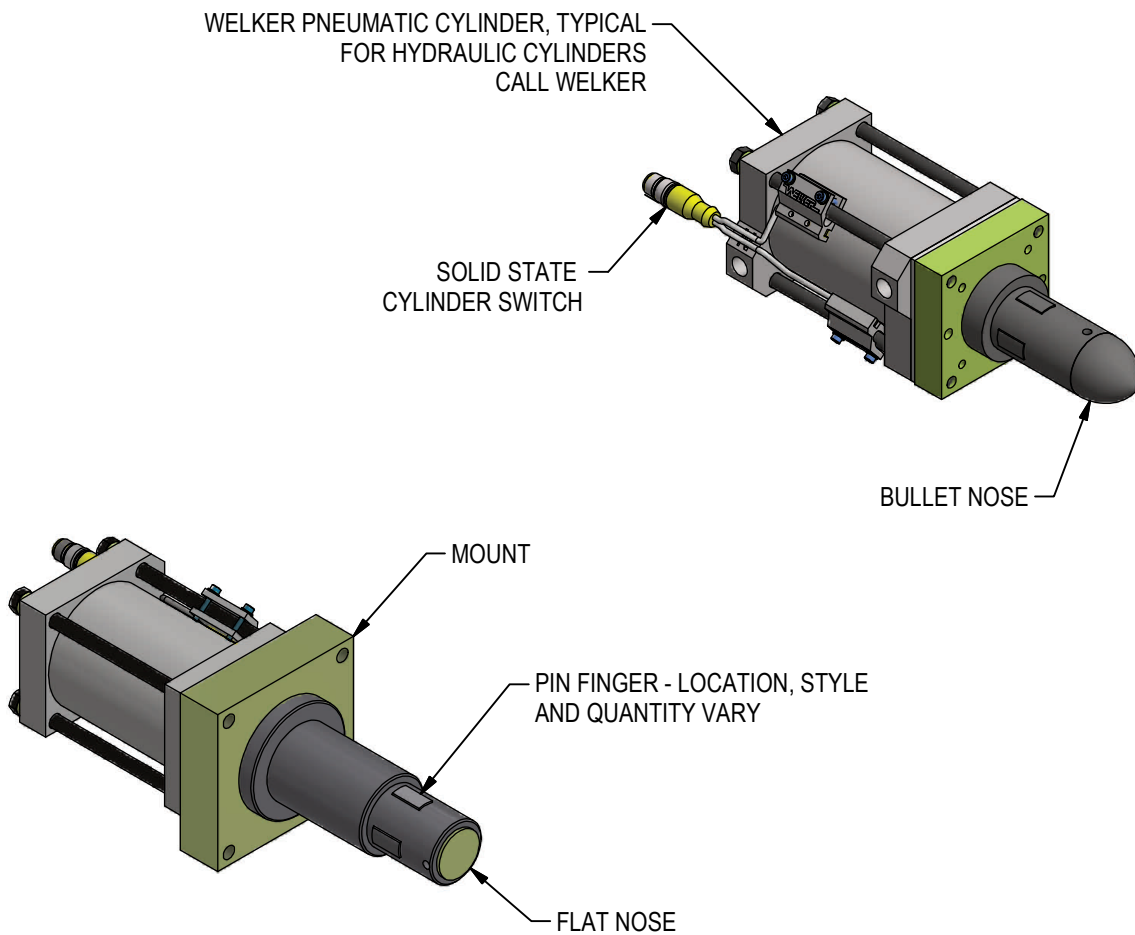

# MAINTENANCE

## **SAFETY FIRST!**

MAINTENANCE SHOULD ONLY BE PERFORMED BY QUALIFIED PERSONNEL. PROPER SAFETY GEAR AND PROCEDURES MUST BE USED AT ALL TIMES.

BEFORE PERFORMING MAINTENANCE, CUT OFF AIR SUPPLY TO THE UNIT, ENSURE THAT ALL AIR IS REMOVED AND THAT THERE ARE NO "TRAPPED AIR" CONDITIONS.

PREVENTATIVE MAINTENANCE: Regularly inspect unit to verify proper operation. Check for debris build up and clean as needed. Inspect all pneumatic, electrical, and mounting connections, making sure all connections are tight and secure. Routine replacement of cylinder seals is recommended.

CYLINDER: Welker pneumatic cylinders are lube free and require very little maintenance. Check for abnormal wear or damage. Plant air supply to the cylinder should be free of contaminants, filtered to a minimum of 50micron and have a water separator. Be sure fittings are in good condition. Seals are subject to wear under normal operating conditions. It is recommended to keep a spare cylinder seal kit or repair kit on hand. For hydraulic cylinders please consult Welker.

SWITCH: Switches may fail and need replacement; it is recommended to keep a spare switch on hand.

# TROUBLESHOOTING

FAILURE	POSSIBLE CAUSE	SOLUTION
Unit fingers do not extend/retract	Cylinder failure	Inspect unit for dirt/debris. Check plant air supply for proper pressure; too little will result in lack of cylinder movement and too much can result in cylinder seal failure. Seals may be worn, damaged or deteriorating. Replace as needed. If cylinder has been serviced, be sure tie rod nuts have been tightened to torque specifications.
Unit fingers do not retract	A very small number of applications with very high heat may require cylinder stop to reduce binding due to thermal expansion.	Add extend stop.
Cylinder switch does not read	Part gets welded through onto fingers	Break part loose. Fix weld path. Check switch for proper operation. Replace as needed.
Cylinder retract (finger extend) switch does not read	Switch must be adjusted to parts at set up	Adjust switch to match part

# REPLACEMENT PARTS

**NOTE A:** When ordering cylinders, repair kits and switches, please have the unit's Welker Job Number available and/or the cylinder model & serial number.

QTY	STOCK*	DESCRIPTION	PART NUMBER
1		PNEUMATIC CYLINDER	CALL WELKER (SEE NOTE A)
1	1	CYLINDER REPAIR KIT	CALL WELKER (SEE NOTE A)
1	1	CYLINDER SWITCH	SEE CHART BELOW

\* RECOMMENDED SPARE PARTS TO KEEP IN STOCK

Reorder #	Mfr. Part Number	Manufacturer	Description
SWITCH L3	SWITCH L3 (weld field immune*, comparable to World Sw itches)	Welker	4-Wire, 4-Pin, DC (PNP)
SWITCH L5	MK5113	ifm Eector	3-Wire, 4-Pin, DC (NPN)

**Standard Switch Option - All other options may affect price and delivery** Sw itches are M12 X 1 Quick Disconnect

\*Note that some mid and low frequency DC resistance applications (i.e. aluminum resistance welding applications) may cause a fault. In these applications, it is recommended that the sensor be ignored/bypassed during the welding cycle.

## CYLINDER SEAL MAINTENANCE

Seals should be replaced routinely to avoid cylinder failure. Please have cylinder model information and/or Welker job number ready when ordering seal kits or repair kits. This information is located on the unit's tag and on the cylinder. Pneumatic cylinder shown below; consult Welker for hydraulic cylinders.

1. Remove air lines from the cylinder. Remove unit from mount. Remove cylinder switch if applicable.
2. Remove the cylinder tie rods & lock washers. Remove end caps & tube.
3. Replace piston seal and bumper seals. Replace outer adapter seal.
4. To access inner adapter seal, remove hex nut and washer from end of cylinder rod. Remove piston. Remove adapter plate, replace inner seal. Replace adapter, piston and washer. Install hex nut on cylinder rod using red Loctite.
5. Align adapter, front end cap, tube, bumper seals and rear end cap on cylinder rod and install to unit body with cylinder tie rods & lock washers. Be sure cylinder ports are in proper position. Using torque wrench tighten bolts to pattern shown. Tighten bolts to 15 ft.lb.
6. Install cylinder switch if applicable. Install unit to mount. Install air lines, making sure they are free of contaminants.

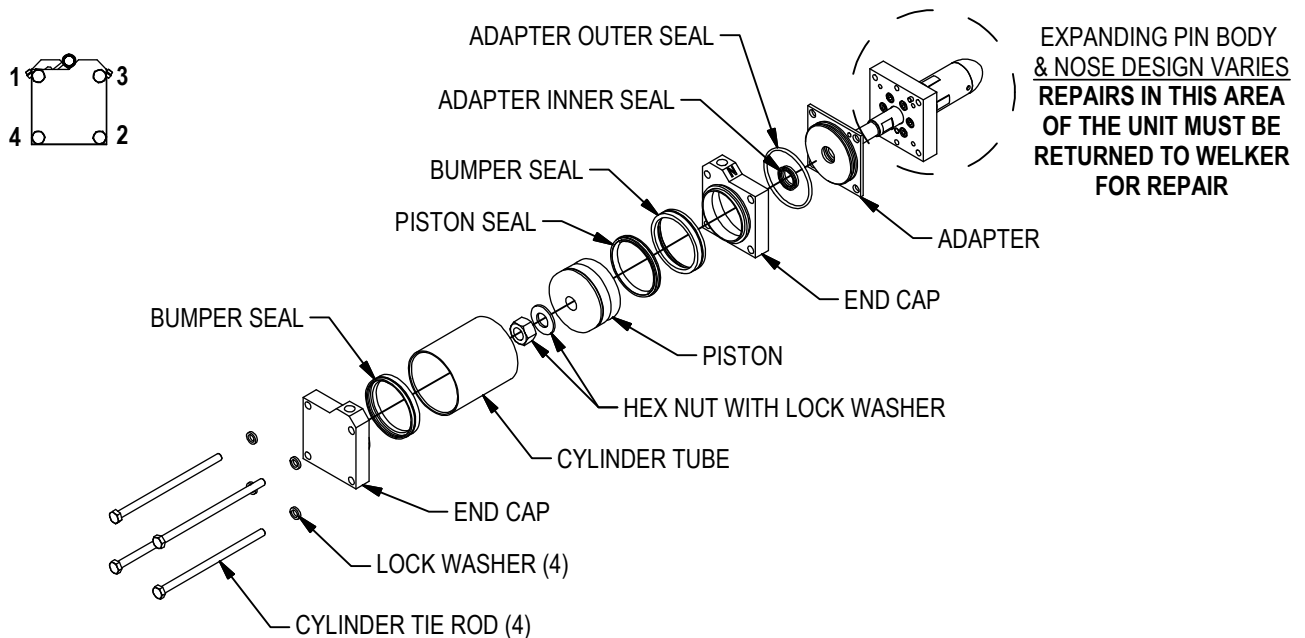

# REPLACING TIE ROD CYLINDER SWITCH

1. BEFORE REMOVING OLD SWITCH: NOTE SENSOR PLACEMENT! FOR SWITCHES WITH TWO SENSORS, EACH WILL BE TAGGED WITH A BAND AROUND THE WIRE INDICATING S1 AND S2 (OR S01 AND S02).
2. TO REMOVE SWITCH, REMOVE BOLTS AND WASHERS FROM BRACKET. SLIDE BRACKET OUT FROM TIE ROD.
3. SENSOR IS SNAPPED INTO BRACKET. REMOVE.
4. INSTALL NEW SWITCH SENSOR FLUSH INTO BRACKET, BEING CAREFUL TO MATCH SENSOR CORRECTLY TO LOCATION ON CYLINDER.
5. LOCATE BRACKET TO CYLINDER, SLIDE ON TO TIE ROD. SECURE WITH BOLTS & WASHERS.

