

PIN CLAMP WORKSHEET

Project	Station #	Date	
Customer	Contact	Email	Phone

NOMINAL HOLE DIAMETER: _____ Tolerance ± _____

Single Metal Thickness: _____ Part print attached

Multiple Metal Quantity: _____ Overall thickness: _____

Will the pin be in geo holes in multiple metal pieces? Yes No

RECOMMENDED PIN DIAMETER:	Series	Application	Pin sizing
	PCZ	geo	0.2mm under minimum
	PCZ	material handling	0.5mm under minimum
	PCS, PCM, PCT, PCY	geo	0.15mm under minimum
	PCS, PCM, PCT, PCY	material handling	0.5mm under minimum

FINGER & PIN CLAMP ORIENTATION

Pin clamp mounted horizontally:

Pin clamp mounted inverted or vertically:

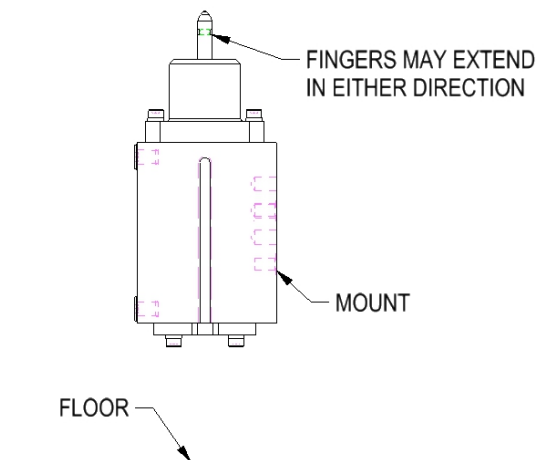
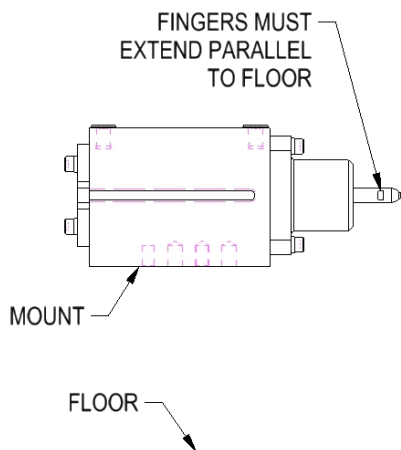

Part # _____	Mounting	<input type="checkbox"/> Horizontal	<input type="checkbox"/> Vertical or inverted
	Fingers	<input type="checkbox"/> @ 0°	<input type="checkbox"/> @ 90°
Part # _____	Mounting	<input type="checkbox"/> Horizontal	<input type="checkbox"/> Vertical or inverted
	Fingers	<input type="checkbox"/> @ 0°	<input type="checkbox"/> @ 90°
Part # _____	Mounting	<input type="checkbox"/> Horizontal	<input type="checkbox"/> Vertical or inverted
	Fingers	<input type="checkbox"/> @ 0°	<input type="checkbox"/> @ 90°