

## MAINTENANCE MANUAL UB SERIES SHOT PINS

### UB4

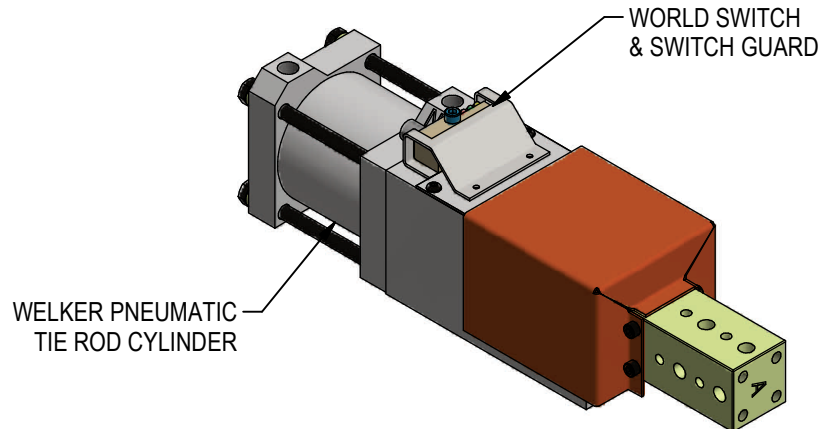

### UB2

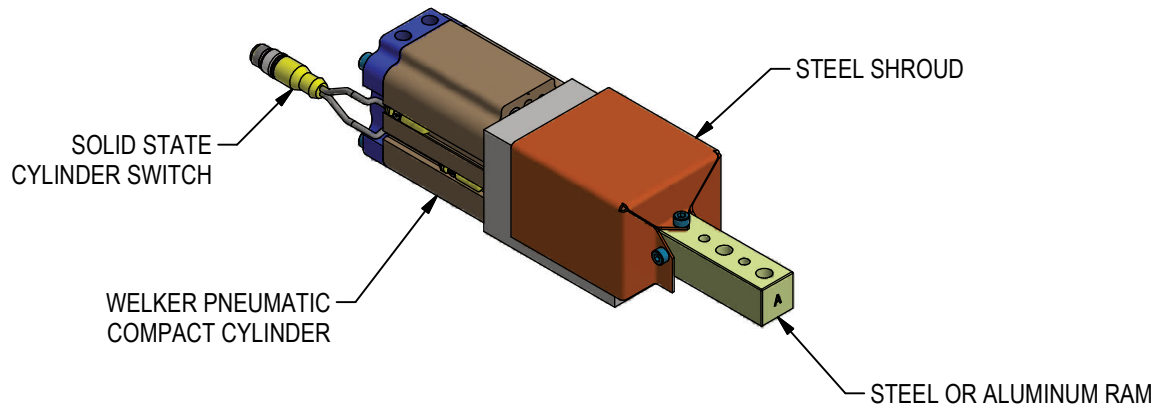

# MAINTENANCE

## **SAFETY FIRST!**

MAINTENANCE SHOULD ONLY BE PERFORMED BY QUALIFIED PERSONNEL. PROPER SAFETY GEAR AND PROCEDURES MUST BE USED AT ALL TIMES.

BEFORE PERFORMING MAINTENANCE, CUT OFF AIR SUPPLY TO THE UNIT, ENSURE THAT ALL AIR IS REMOVED AND THAT THERE ARE NO "TRAPPED AIR" CONDITIONS.

PREVENTATIVE MAINTENANCE: Regularly inspect unit to verify proper operation. Check for debris build up and clean as needed. Inspect all pneumatic, electrical, and mounting connections, making sure all connections are tight and secure.

CYLINDER: Pneumatic cylinders are integral to the UB series shot pins and are not replaceable. If unit fails to function properly, replace entire unit. Check for abnormal wear or damage. Plant air supply to the cylinder should be free of contaminants, filtered to a minimum of 50 micron and have a water separator. Be sure fittings are in good condition.

SWITCH: Switches may fail and need replacement; it is recommended to keep a spare switch on hand.

WIPER: Welker recommends annual changing of urethane wiper. Wipers are maintenance items and are not covered under standard product warranty.

DETENT: Detent option's ball spring plunger is a wear item, not covered under standard warranty. Annual replacement is recommended.

WELKER RECOMMENDS IN-PLANT RECERTIFICATION AFTER SERVICE/REPAIR/REPLACEMENT.

# TROUBLESHOOTING

FAILURE	POSSIBLE CAUSE	SOLUTION
Unit does not extend/retract.	Cylinder failure Switch failure	Inspect unit for dirt/debris.  Check plant air supply for proper pressure; too little will result in lack of cylinder movement.  Seals may be worn, damaged or deteriorating. Pneumatic cylinders are integral to the UB series shot pins and are not replaceable. If unit fails to function properly, replace entire unit.  Check switch for proper operation. Replace as needed.

# REPLACEMENT PARTS

QTY	STOCK*	DESCRIPTION	PART NUMBER
1	1	SWITCH	SEE CHART BELOW
1	1	UB2 WIPER	WIPER-24
1	1	UB4 WIPER	WIPER-40-KIT
1	1	UB2 DETENT OPTION SPRING PLUNGER	3126A56
1	1	UB4 DETENT OPTION SPRING PLUNGER	3126A56

\* RECOMMENDED SPARE PARTS TO KEEP IN STOCK

	Reorder #	Mfr. Part Number	Manufacturer	Description
<b>World Switches</b>	<b>SWA</b>	Ni2-Q6.5-AP6-0.1-FS 4.4X3/S304	Turck	4-Wire, 4-Pin, DC M12 X 1 (PNP) Quick Disconnect
	<b>SWB</b>	Ni2-Q6.5-ADZ32-0.1-FSB 5.4X4/S304	Turck	4-Wire, 5-Pin, AC/DC 1/2-20 (N.O.) Quick Disconnect
	<b>SWC</b>	Ni2-Q6.5-AN6-0.1-FS 4.4X3/S304	Turck	4-Wire, 4-Pin, DC M12 X 1 (NPN) Quick Disconnect
	<b>SWD</b>	NBN2-F581-100S6-E8-V1	Pepperl & Fuchs	4-Wire, 4-Pin, DC M12 X 1 (PNP) Quick Disconnect
	<b>SWE (UB4 ONLY)</b>	BES-Z02KR2-PSC20F-P100-S04-V	Balluff	3-Wire, 4-Pin, DC M12 X 1 (PNP) Quick Disconnect
	<b>SWJ</b>	IN5374	Efector	3-Wire, 4-Pin, DC M12 X 1 (PNP) Quick Disconnect
	Reorder #	Mfr. Part Number	Manufacturer	Description
<b>Cylinder Switches</b>	<b>SWITCH L3</b>	SWITCH L3 L3 switch is weld field immune, comparable to World Switches	Welker	4-Wire, 4-Pin, DC M12 X 1 (PNP) Quick Disconnect
	<b>SWITCH L5</b>	MK5113	ifm Efector	3-Wire, 4-Pin, DC M12 X 1 (NPN) Quick Disconnect

**Standard Switch Option - All other options may affect price and delivery**

# WORLD SWITCH INSTALLATION: UB4

1. REMOVE SHROUD (4 SCREWS).
2. REMOVE UNIT COVER PLATE (4 SCREWS).
3. FULLY EXTEND RAM.
4. LOCATE M6 X 16 SHOULDER SCREW IN RAM. CALL WELKER IF SHOULDER SCREW IS MISSING.
5. INSTALL PINS IN SWITCH SENSORS, 2 PER SENSOR.
6. INSTALL SWITCH INTO SHOT PIN BODY USING SWITCH FASTENER.
7. INSTALL SWITCH SENSORS IN UNIT BODY: FOR RETRACT OPTION INSTALL SENSOR S01 IN FIXED SLOT; INSTALL S02 IN OBLONG SLOT. FOR EXTEND OPTION INSTALL SENSOR S02 IN FIXED SLOT; INSTALL S01 IN OBLONG SLOT.
8. INSTALL SECOND SENSOR IN OBLONG SLOT, ALIGNING CENTER MARK TO CENTER OF SHOULDER BOLT IN RAM. *FOR LONG STROKE UNITS, SECOND SENSOR MAY NEED TO BE INSTALLED UPSIDE DOWN. INSTALL PINS IN OPPOSITE SIDE OF SENSOR. SECURE WIRE IN OBLONG SLOT WITH EXTRA PIN SO IT DOESN'T INTERFERE WITH UNIT OPERATION.*
9. INSTALL COVER PLATE AND SHROUD.

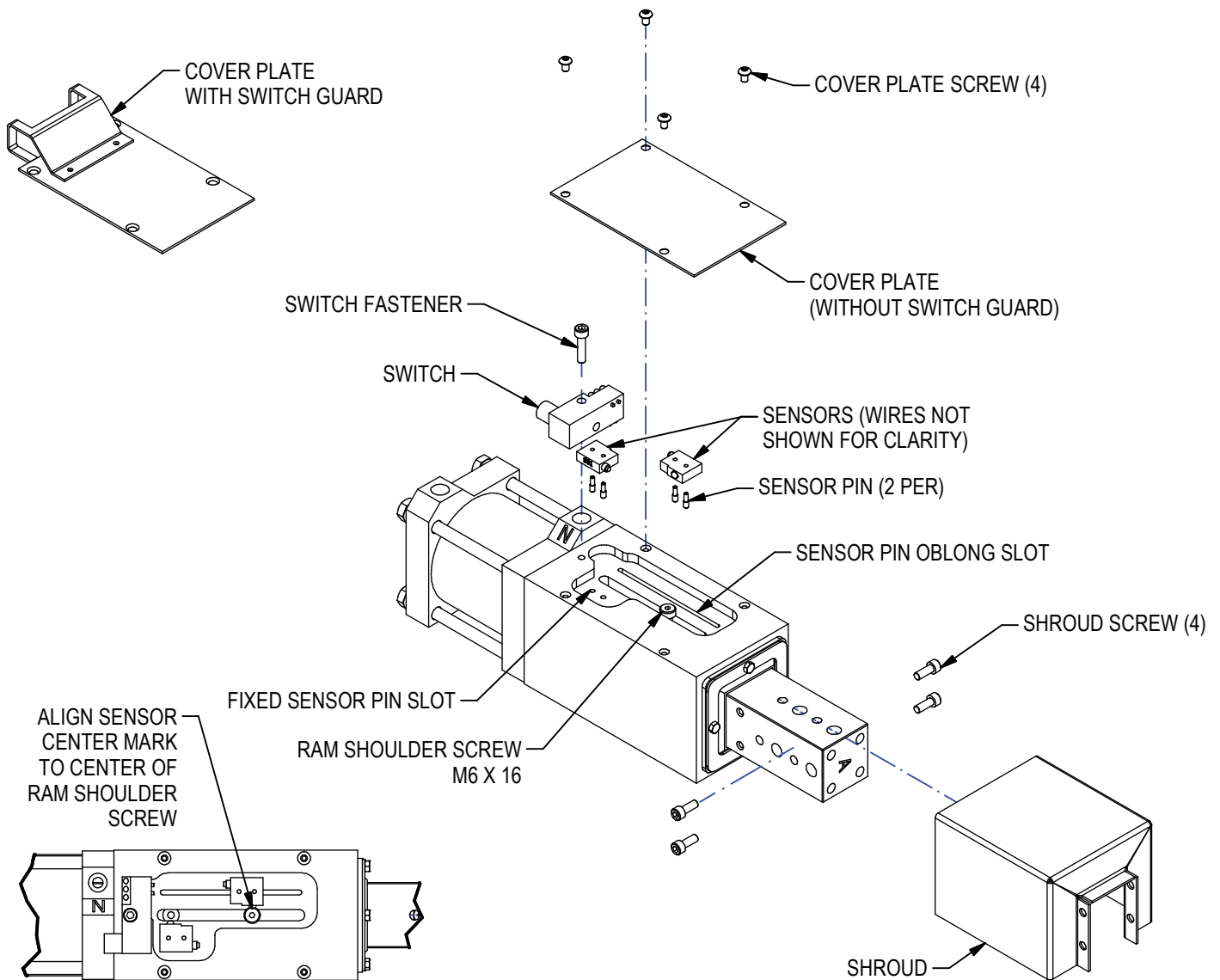

# WORLD SWITCH INSTALLATION: UB2

1. REMOVE SHROUD (3 SCREWS).
2. REMOVE UNIT COVER PLATE (4 SCREWS).
3. REMOVE SWITCH FASTENER AND SWITCH GUARD. REMOVE OLD SWITCH AND SENSORS NOTING SENSOR S01 AND S02 (OR S1 AND S2) POSITION IN UNIT BODY..
4. INSTALL PINS IN SWITCH SENSORS, 2 PER SENSOR.
5. INSTALL SENSOR SPACERS TO SENSOR PINS. POSITION SENSORS IN UNIT BODY, SAME LOCATIONS AS OLD SWITCH.
6. INSTALL SWITCH AND SWITCH GUARD TO SHOT PIN BODY WITH FASTENERS.
7. INSTALL COVER PLATE AND SHROUD.

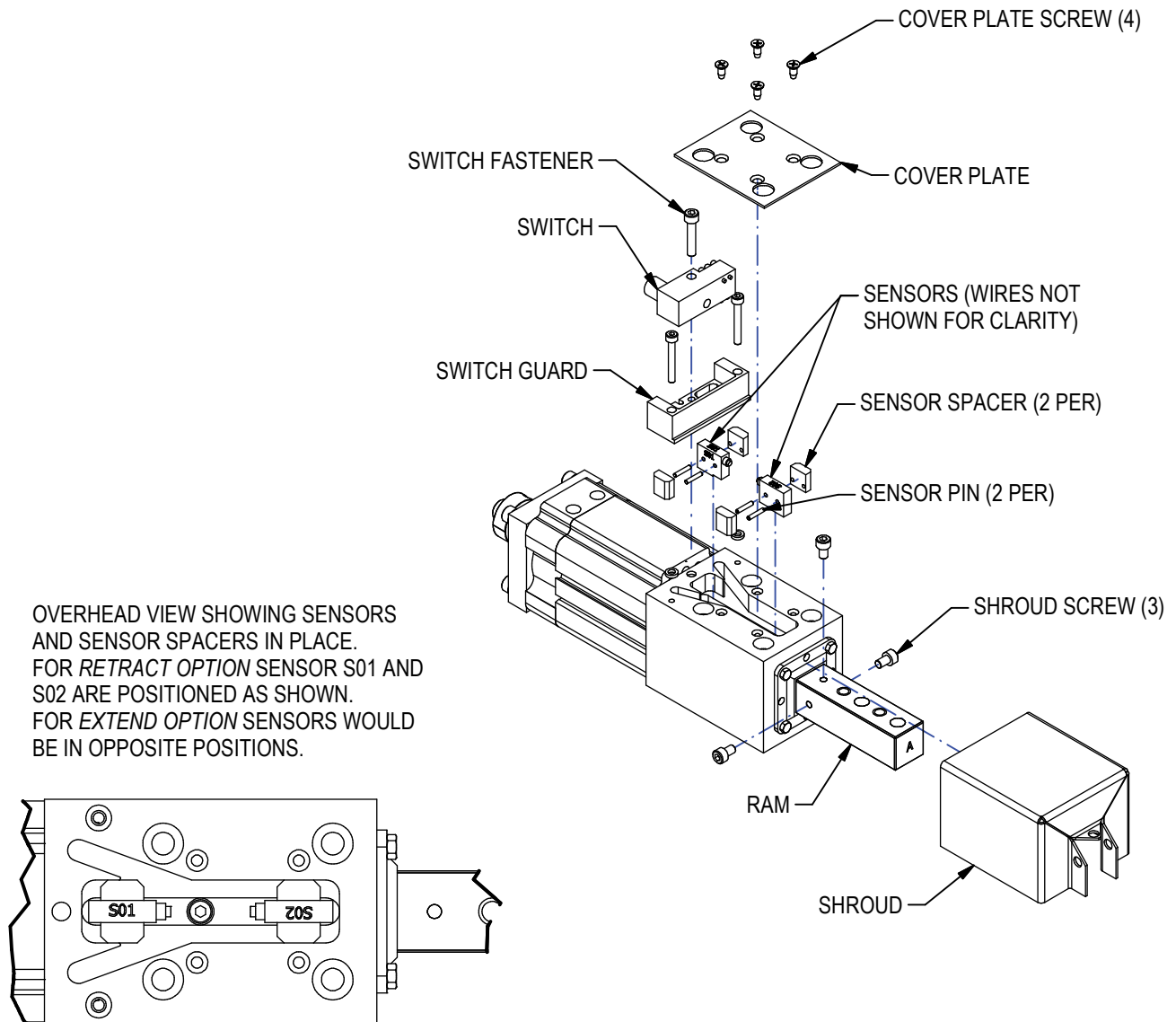

## WIPER MAINTENANCE

Welker recommends annual changing of urethane wiper. Wipers are maintenance items and are not covered under standard product warranty. Steam cleaning or wiping contamination off during the course of normal machine maintenance is desirable.

1. Disengage plant air from unit. Remove tooling from unit ram.
2. Remove shroud screws. Remove shroud.
3. Remove wiper screws. Remove wiper retainer (UB4 only). Remove wiper.
4. Clean ram, removing residual debris.
5. Install new wiper using a small amount of Magnalube G grease.
6. Replace wiper retainer (UB4 only).
7. Install wiper screws.
8. Install shroud with shroud screws.
7. Install tooling on unit ram.
8. Engage plant air, making sure lines are free of contaminants.

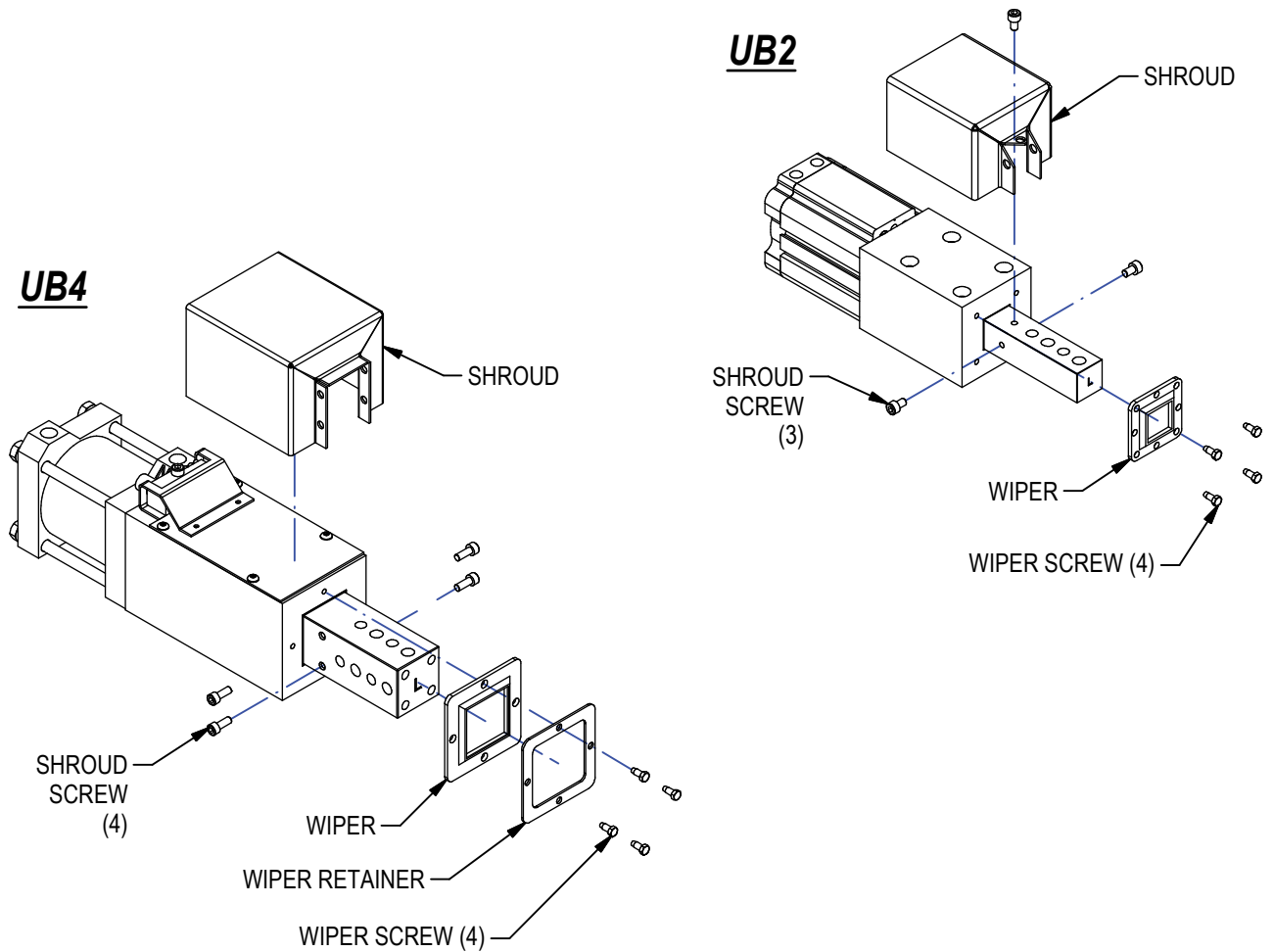

# DETENT OPTION MAINTENANCE

Detent option's ball spring plunger is a maintenance item, not covered under standard product warranty.

1. Disengage plant air from unit. Remove tooling from unit ram.
2. Remove shroud screws. Remove shroud.
3. Note location of plunger. Unit body features holes on both sides for detent option. Plunger is installed according to rap/rigid coupler option. Units with rigid coupler option, plunger will be located as shown below. Units with rap coupler option, plunger will be on opposite side. A set screw is installed in non-plunger hole.
4. Remove plunger noting depth in unit body.
5. Clean any debris from unit.
6. Install new plunger to same depth as old. Plunger includes thread locking element. Do not install plunger deeper than original plunger.
7. Install shroud with shroud screws.
8. Engage plant air, making sure lines are free of contaminants.

