

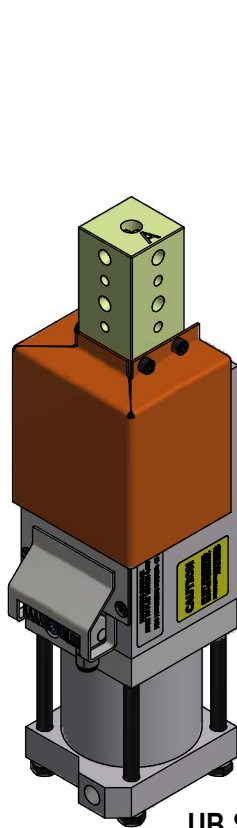

ISO 9001:2015 REGISTERED
ENGINEERED PRODUCTS

RAP/RIGID CONVERSION FOR SHOT PINS

RAP OPTION CAUSES CYLINDER PISTON TO ACT AS A SLIDE HAMMER



UB SERIES

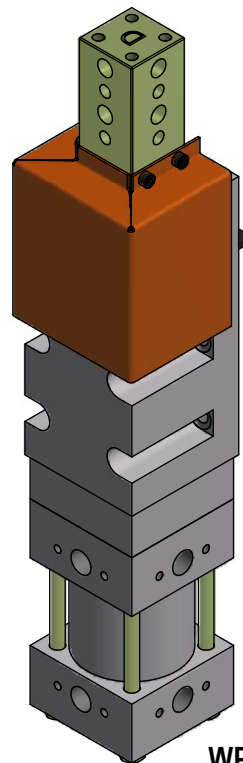

WP SERIES

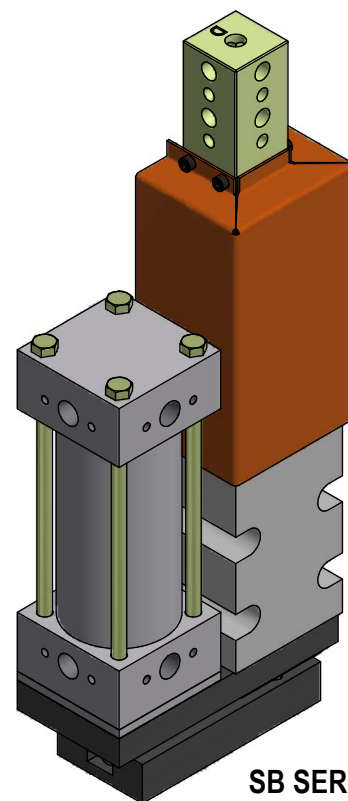

SB SERIES

INLINE SHOT PINS

SIDE-BY-SIDE SHOT PINS

RAP TO RIGID CONVERSION FOR UB SERIES INLINE SHOT PINS ~ CLIP STYLE

1. Remove air line, release air pressure. Move ram to retracted position.
2. Remove cylinder tie rods and lock washers.
3. Remove end cap, cylinder seal and cylinder tube.
4. Locate rigid adapter to rap or rigid position as shown.
5. For units with detent option, see sheet 4.

NOTES:

*RAP OPTION DECREASES
EXTEND STROKE BY 2mm*

*RAP OPTION NOT AVAILABLE
ON DOUBLE ROD CYLINDERS*

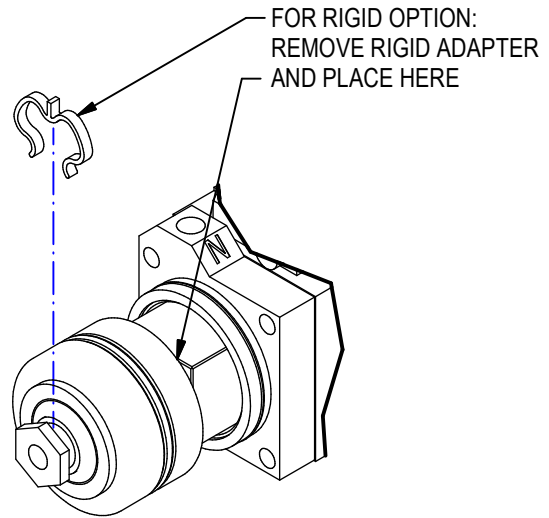
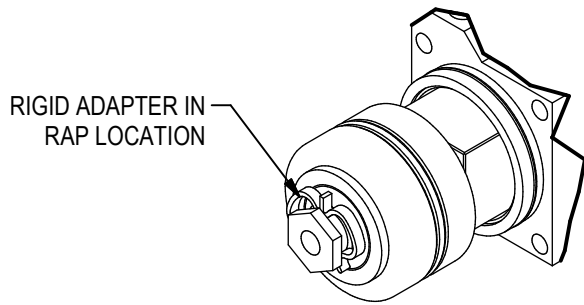
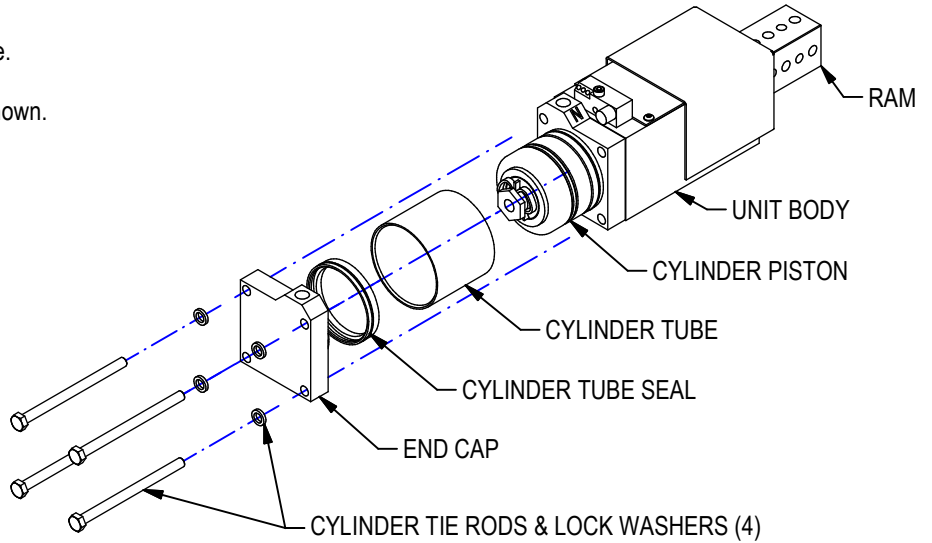

6. Reassemble unit, reversing steps 1, 2 and 3. Be sure cylinder ports are in proper position.
7. Using a torque wrench, tighten cylinder tie rods to torque specifications. Tighten to pattern shown.

TORQUE SPECIFICATIONS				
SHOT PIN	THREAD	ft-lbf.	in-ibf	N-m
UB2	1/4"-28	6.5	78	8.8
UB4	5/16"-24	12	144	16.3

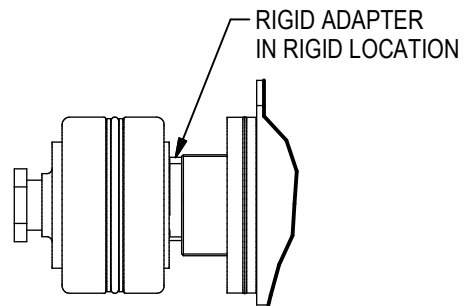
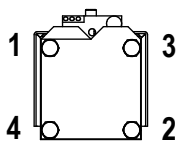

RAP TO RIGID CONVERSION FOR UB SERIES INLINE SHOT PINS ~ RIGID COUPLER ADAPTER

1. Remove air line, release air pressure. Move ram to retracted position.
2. Remove cylinder tie rods and lock washers.
3. Remove end cap, cylinder seal and cylinder tube.
4. Locate rigid coupler adapter to rigid position or remove for rap option as shown.
5. For units with detent option, see sheet 4.

NOTES:

*RAP OPTION DECREASES
EXTEND STROKE BY 2mm*

*RAP OPTION NOT AVAILABLE
ON DOUBLE ROD CYLINDERS*

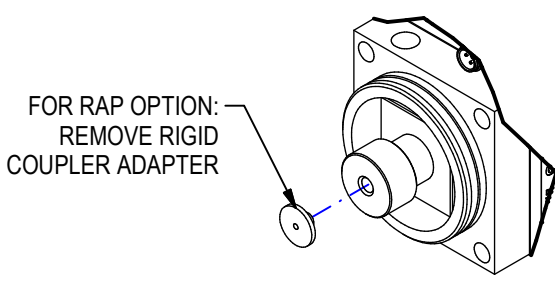
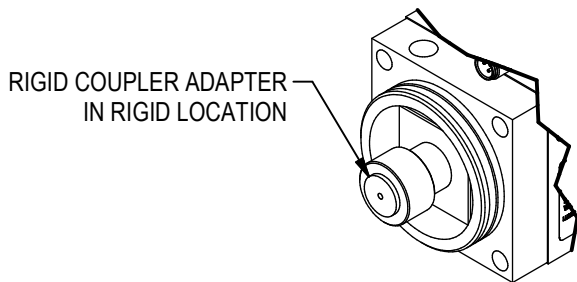
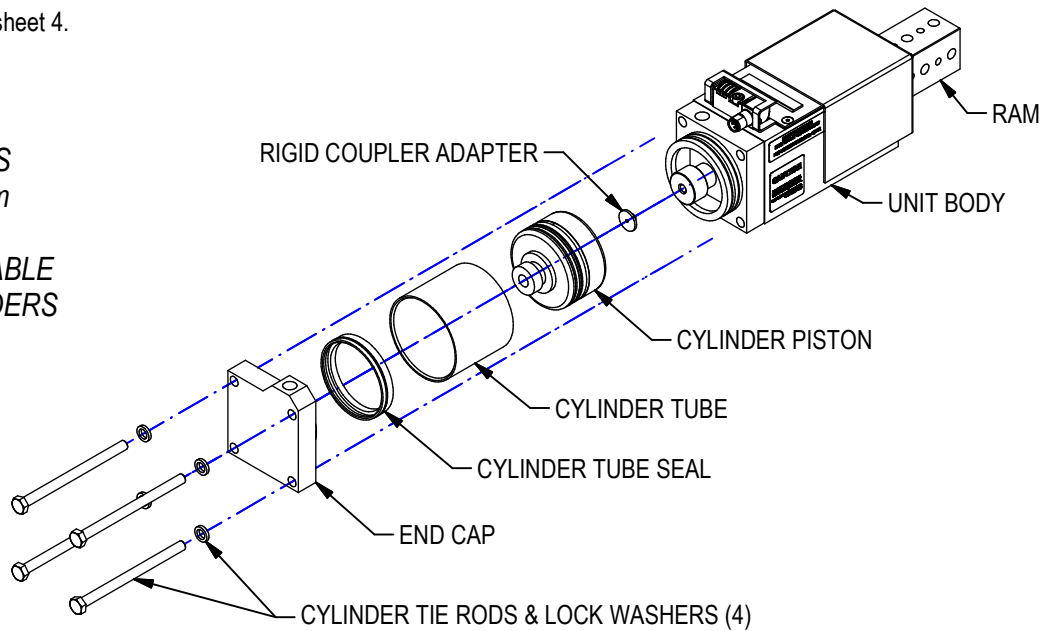

6. Reassemble unit, reversing steps 1, 2 and 3. Be sure cylinder ports are in proper position.

7. Using a torque wrench, tighten cylinder tie rods to torque specifications. Tighten to pattern shown.

TORQUE SPECIFICATIONS				
SHOT PIN	THREAD	ft-lbf.	in-ibf	N-m
UB2	1/4"-28	6.5	78	8.8
UB4	5/16"-24	12	144	16.3

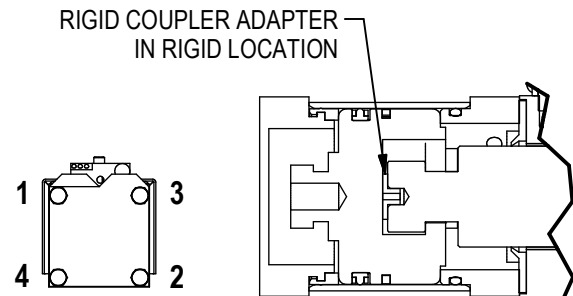

FOR UNITS WITH DETENT OPTION ~ UB2 AND UB4 ONLY

Detent option's ball spring plunger is located in unit body in relation to rap or rigid coupler. If changing rigid coupler adapter location from rap to rigid, the plunger location must also be addressed.

1. Disengage plant air from unit. Remove tooling from unit ram.
2. Remove shroud screws. Remove shroud.
3. **Note location of plunger. Unit body features holes on both sides for detent option. Units with rigid coupler option, plunger will be located as shown below. Units with rap coupler option, plunger will be on opposite side. A set screw is installed in non-plunger hole.**
4. Remove plunger noting depth in unit body.
5. Remove set screw from opposite side of unit body.
6. Clean any debris from unit.
7. Install plunger to opposite side, same depth as old. New plunger includes thread locking element. If relocating an existing plunger, install with removable thread adhesive. Do not install plunger deeper than original plunger.
8. Install shroud with shroud screws.
9. Engage plant air, making sure lines are free of contaminants.

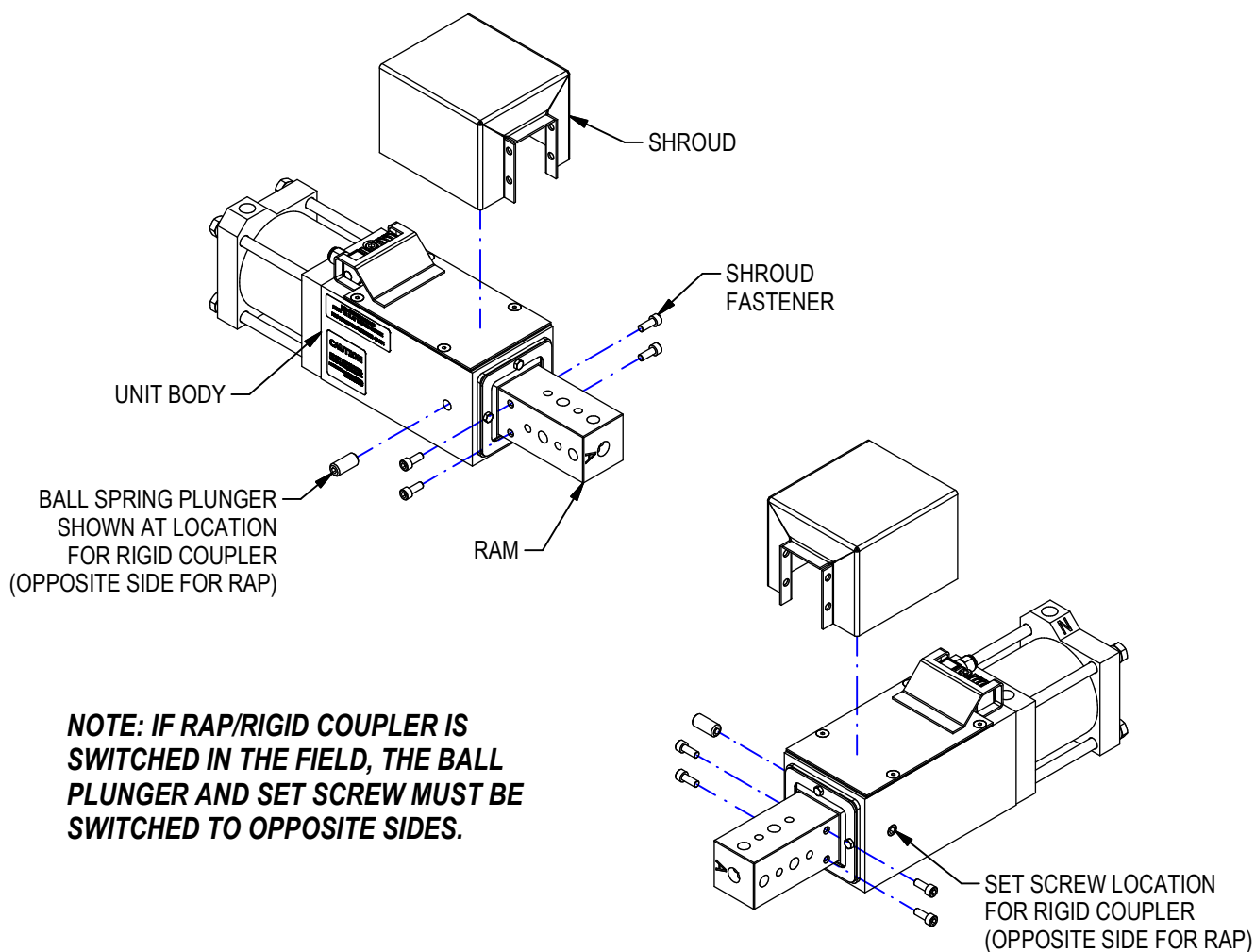

NOTE: IF RAP/RIGID COUPLER IS SWITCHED IN THE FIELD, THE BALL PLUNGER AND SET SCREW MUST BE SWITCHED TO OPPOSITE SIDES.

RAP TO RIGID CONVERSION FOR WP SERIES INLINE SHOT PINS

1. Remove air line, release air pressure. Move ram to retracted position.
2. Remove shroud fasteners (4). Remove shroud.
3. Loosen cylinder tie rods enough to free cylinder from unit body.
4. Pull cylinder away from unit body enough to disengage cylinder coupler from slot.
5. Rigid coupler adapter is installed to cylinder coupler for rigid option. Rigid coupler adapter is removed for rap option.

NOTES:

RAP OPTION DECREASES EXTEND STROKE BY 2mm ON WP2 & WP4; 3mm ON WP6

RAP OPTION NOT AVAILABLE ON DOUBLE ROD CYLINDERS

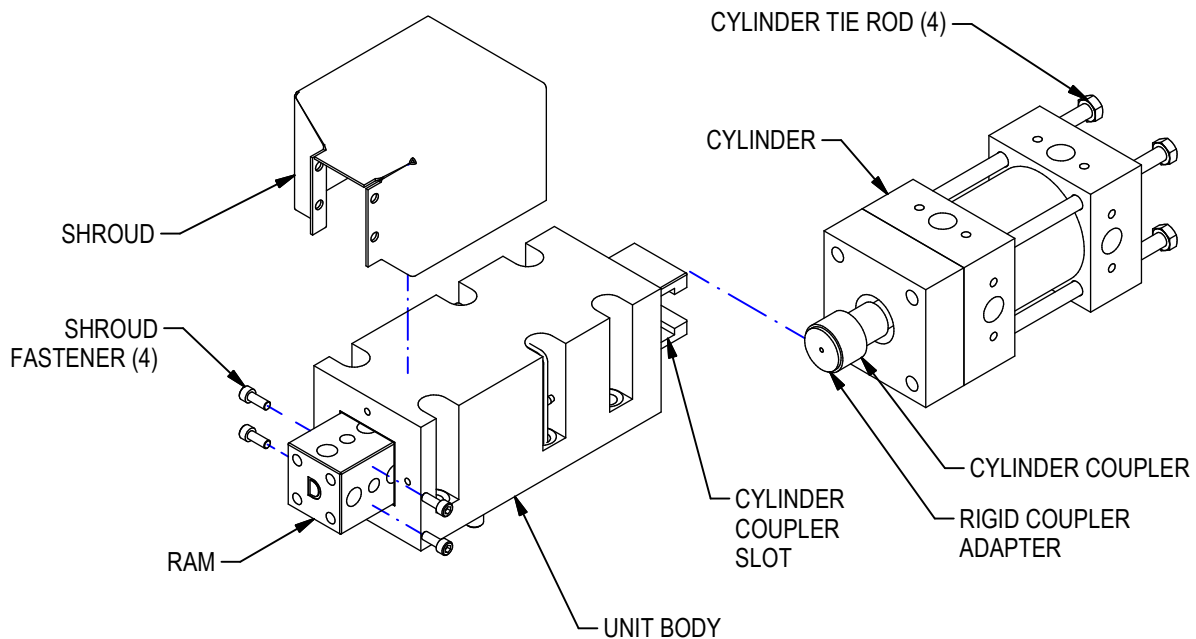

5. Reassemble unit, reversing steps 1, 2, 3 and 4. Be sure cylinder ports are in proper position.
6. Using a torque wrench, tighten cylinder tie rods to torque specifications. Tighten to pattern shown.

TORQUE SPECIFICATIONS				
SHOT PIN	THREAD	ft-lbf.	in-ibf	N-m
WP2	1/4"-28	6.5	78	8.8
WP4	5/16"-24	12	144	16.3
WP6	3/8"-24	22	264	29.8

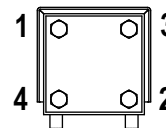

RAP TO RIGID CONVERSION FOR SB SERIES SIDE-BY-SIDE SHOT PINS

1. Remove air line, release air pressure. Move ram to retracted position.
2. Remove tie bar screw.
3. Slide tie bar away from cylinder coupler.
4. Rigid coupler adapter is installed to cylinder coupler for rigid option. Rigid coupler adapter is removed for rap option.
5. Reassemble unit, reversing steps 1, 2 and 3.

NOTE

*RAP OPTION DECREASES RAM RETRACT STROKE BY 2mm ON SB2 & SB4; 3mm ON SB6.
SEE CATALOG FOR DETAILS.*

