

X-Y SERVO SHIM POSITIONER S01474 MAINTENANCE MANUAL

DUAL AXIS

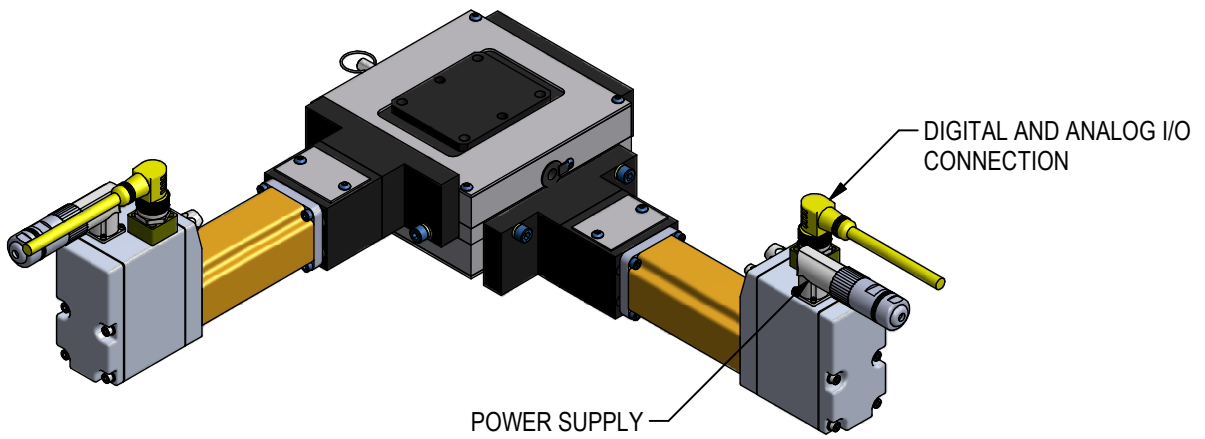

SINGLE AXIS

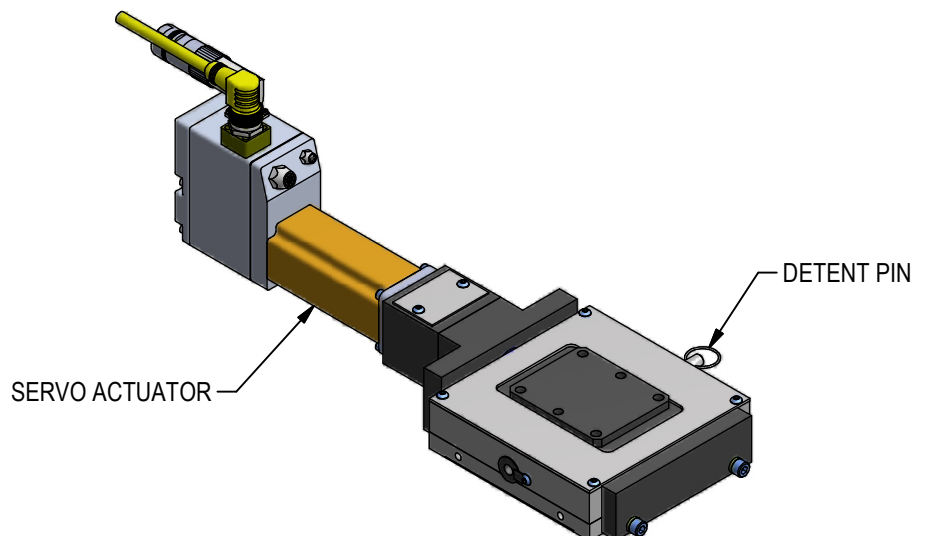

MAINTENANCE

SAFETY FIRST!

MAINTENANCE SHOULD ONLY BE PERFORMED BY QUALIFIED PERSONNEL. PROPER SAFETY GEAR AND PROCEDURES MUST BE USED AT ALL TIMES.

BEFORE PERFORMING MAINTENANCE, CUT OFF POWER SUPPLY TO THE UNIT. SECURE UNIT IN CENTER POSITION WITH DETENT PINS INSTALLED TO PREVENT MOTION.

PREVENTATIVE MAINTENANCE: Regularly inspect unit to verify proper operation. Check for debris build up and clean as needed. Inspect all electrical and mounting connections, making sure connections are tight and secure.

TROUBLESHOOTING

Trouble	Possible Cause/Troubleshooting Procedure
Unit does not move or does not travel full distance	Detent pin engaged. Inspect unit for dirt/debris.
No response from actuator	Check drive for faults that may indicate problem via I/O or software. Check to ensure that drive is powered and enabled. Check for proper wiring.
Actuator seems to be enabled (receiving current) but is not operating or is operating erratically	Drive may be improperly tuned. Check all gain settings. Check for load irregularities or excess compliance.
Actuator cannot move load	Load is too large for the capacity of the actuator or too much friction is present. Excessive side load. Current limit in drive is set too low. Power supply has too low of current capacity.
Actuator housing moves or vibrates when shaft is in motion	Check actuator mounting. Ensure that the actuator is securely mounted. Drive is improperly tuned (wrong gain settings).
Actuator is overheating	Insufficient cooling for application requirements. Ambient temperature is too high. Actuator is being operated outside of continuous ratings. Amplifier is poorly tuned causing excessive unnecessary current to be applied to motor. Check gain settings. Over Voltage limit set too low causing internal shunt control to remain active.

REPLACEMENT PARTS

NOTE A: When ordering replacement actuators, please have the unit's Welker Job Number available and/or the motor's model & serial number.

REPLACEMENT PARTS				
ITEM	QTY	STOCK*	DESCRIPTION	PART NUMBER
1	1		SERVO ACTUATOR	SEE CHART BELOW

* RECOMMENDED SPARE PARTS TO KEEP IN STOCK

MOTOR INFO:

EXLAR TRITEX II DC GEARMOTOR, 24/48 VDC
5:1 GEAR REDUCTION
ABSOLUTE FEEDBACK
ETHERNET IP (SEALED M12 CONNECTOR)
UP TO 16 PROGRAMMED POSITIONS
ALL PROGRAMING TO BE DONE BY CUSTOMER

MOTOR PIN CONFIGURATION:

PIN 1 = 24 VDC BUS POWER
PIN 2 = 24 VDC LOGIC POWER PLUS
PIN 3 = GROUND
PIN 4 = 24 VDC COMMON POWER AND LOGIC

SLIDE INFO:

MAX LOAD: 150lbf
TRAVEL: 1 in/sec
5/8-10 ACME GROUND THREAD
SELF-LOCKING SCREW

WEIGHT INFO:

SINGLE: 21.1 lbs
DOUBLE: 38.4 lbs

REPLACING ACTUATOR

1. Disconnect all power to unit.
2. Remove actuator mounting screws.
3. Pull actuator to dislodge from coupling. Coupling is a 3-piece unit: aluminum hub A is mounted to slide, aluminum hub B is mounted to actuator, elastomer insert fits between.
4. Remove coupler hub B from old actuator, mount to new actuator.
5. Install insert to coupler hub B.
6. Remove cover plate for visual access to coupler for assembly.
7. Align coupler assembly and press in new actuator.
8. Install cover plate.
9. Install actuator mounting screws.

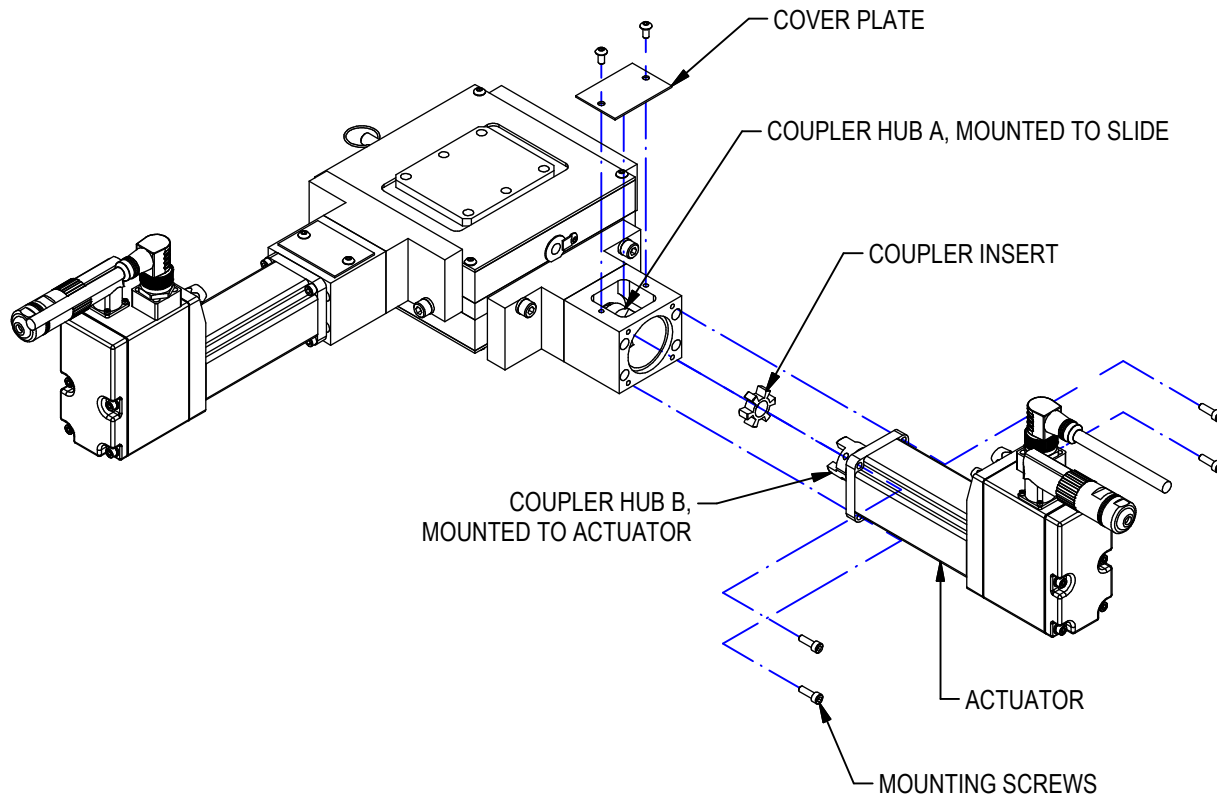

Tightening Torques for Metric Bolts (installed dry)				
	Steel		Aluminum	
M5	10 Nm	7.375 ft lb.	5 Nm	3.6875 ft lb.
M6	19 Nm	14.014 ft lb.	9.5 Nm	7.007 ft lb.
M8	45 Nm	33.19 ft lb.	22.5 Nm	16.595 ft lb.
M10	89 Nm	65.643 ft lb.	44.5 Nm	32.8215 ft lb.
M12	156 Nm	115.06 ft lb.	78 Nm	57.53 ft lb.