

MAINTENANCE MANUAL SB SERIES SIDE-BY-SIDE SHOT PINS

SB2

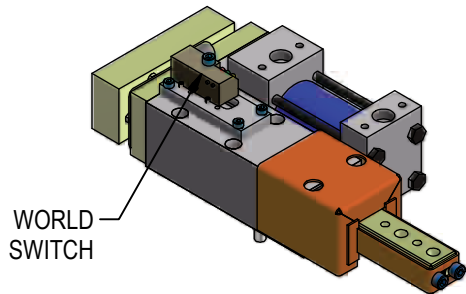

SB4

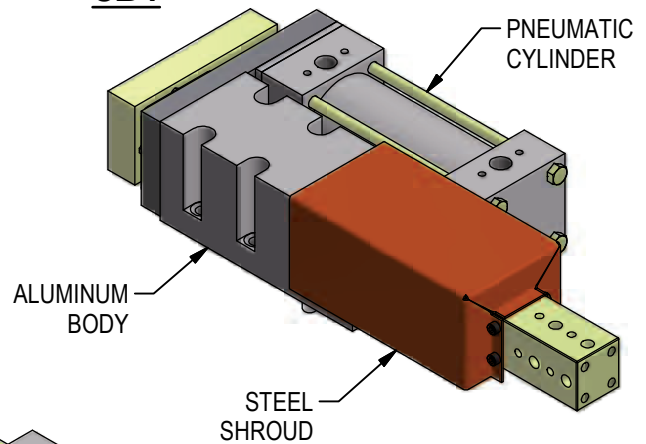

SB6

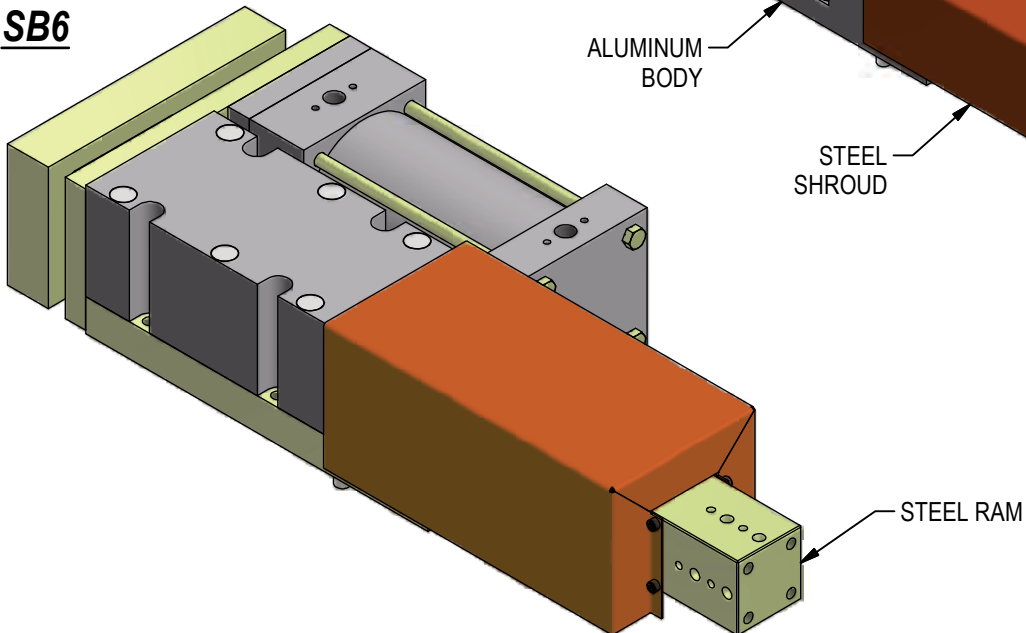

MAINTENANCE

SAFETY FIRST!

MAINTENANCE SHOULD ONLY BE PERFORMED BY QUALIFIED PERSONNEL. PROPER SAFETY GEAR AND PROCEDURES MUST BE USED AT ALL TIMES.

BEFORE PERFORMING MAINTENANCE, CUT OFF AIR SUPPLY TO THE UNIT, ENSURE THAT ALL AIR IS REMOVED AND THAT THERE ARE NO "TRAPPED AIR" CONDITIONS.

PREVENTATIVE MAINTENANCE: Regularly inspect unit to verify proper operation. Check for debris build up and clean as needed. Inspect all pneumatic, electrical, and mounting connections, making sure all connections are tight and secure.

CYLINDER: Welker pneumatic cylinders are lube free and require very little maintenance. Check for abnormal wear or damage. Plant air supply to the cylinder should be free of contaminants, filtered to a minimum of 50micron and have a water separator. Be sure fittings are in good condition. Seals are subject to wear under normal operating conditions. It is recommended to keep a spare cylinder seal kit on hand.

SWITCH: Switches may fail and need replacement; it is recommended to keep a spare switch on hand.

WIPER: Welker recommends annual changing of urethane wiper. Wipers are maintenance items and are not covered under standard product warranty.

TROUBLESHOOTING

FAILURE	POSSIBLE CAUSE	SOLUTION
Unit does not extend/retract.	Cylinder failure Switch failure	Inspect unit for dirt/debris. Check plant air supply for proper pressure; too little will result in lack of cylinder movement. Seals may be worn, damaged or deteriorating. Replace as needed. If cylinder has been serviced, be sure tie rod nuts have been tightened to torque specifications. Check switch for proper operation. Replace as needed.

REPLACEMENT PARTS

QTY	STOCK*	DESCRIPTION	PART NUMBER
1	1	WORLD SWITCH (SB2 ONLY)	SEE CHART BELOW
2	1	SB2 WIPER	WIPER-24
	1	SB2 PNEUMATIC CYLINDER SEAL KIT	WSMCYL-24-CSK
		SB2 PNEUMATIC CYLINDER, NPT PORTS	WSMCYL-24(STROKE-2mm)-A-SB2
		SB2 PNEUMATIC CYLINDER, G PORTS	WCP-053-STROKE-SB2
2	1	SB4 WIPER	WIPER-40-KIT
	1	SB4 PNEUMATIC CYLINDER SEAL KIT	WC-002-CSK
		SB4 PNEUMATIC CYLINDER, NPT PORTS	WC-002-STROKE-SB4
		SB4 PNEUMATIC CYLINDER, G PORTS	WC-032-STROKE-SB4
2	1	SB6 WIPER	WIPER-60
	1	SB6 PNEUMATIC CYLINDER SEAL KIT	WC-1002-CSK
		SB6 PNEUMATIC CYLINDER, NPT PORTS	WCP-1002-STROKE-SB6
		SB6 PNEUMATIC CYLINDER, G PORTS	WCP-054-STROKE-SB6

* RECOMMENDED SPARE PARTS TO KEEP IN STOCK

World Switches Note: Available with 25mm and 50mm	Reorder #	Manufacturer Part Number	Manufacturer	Description
	SWA	Ni2-Q6.5-AP6-0.1-FS 4.4X3/S304	Turck	3-Wire, 4-Pin, DC M12 X 1 (PNP) Quick Disconnect
	SWB	Ni2-Q6.5-ADZ32-0.1-FSB 5.4X4/S304	Turck	4-Wire, 5-Pin, AC/DC 1/2-20 (N.O.) Quick Disconnect
	SWD	NBN2-F581-100S6-E8-V1	Pepperl & Fuchs	3-Wire, 4-Pin, DC M12 X 1 (PNP) Quick Disconnect
	SWJ	IN5374	Efector	4-Wire, 4-Pin, DC M12 X 1 (PNP) Quick Disconnect

Standard Switch Option - All other options may affect price and delivery

REPLACING WORLD SWITCH

1. Disengage plant air from unit. Disconnect M12 connector.
2. Remove screws from switch housing (4).
3. Remove switch screw, remove switch and sensors noting sensor location in unit body. Sensors are marked S1 and S2 or S01 and S02.
4. Thread new switch sensors thru switch housing, install to unit body.
5. Wrap wires behind sensors in slot.
6. Secure switch to switch housing. Mount switch housing to unit body using screws (4).
7. Test to check new switch and verify sensor position.

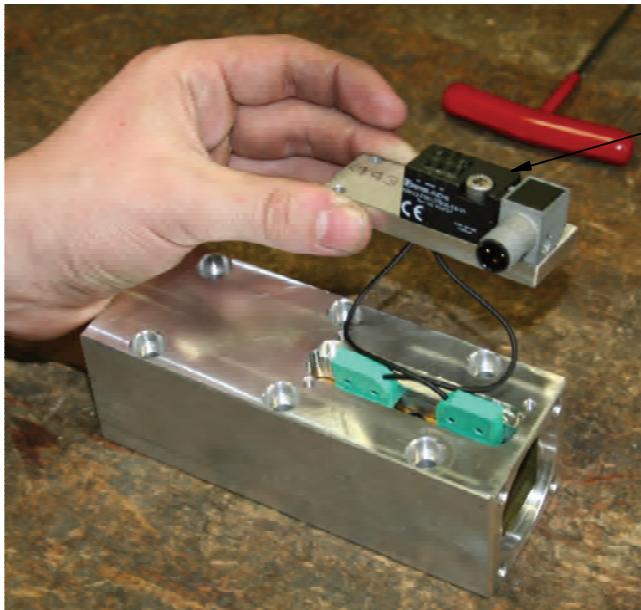
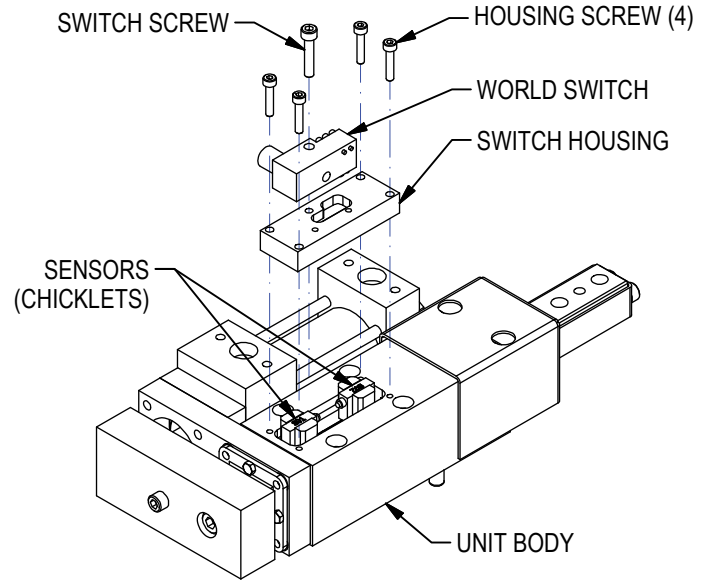

TO M12 4-PIN CONNECTOR

INNER EXTRUSION MAINTAINS SWITCH PEGS IN PLACE

WIRES GET WRAPPED BEHIND

SENSOR PEG

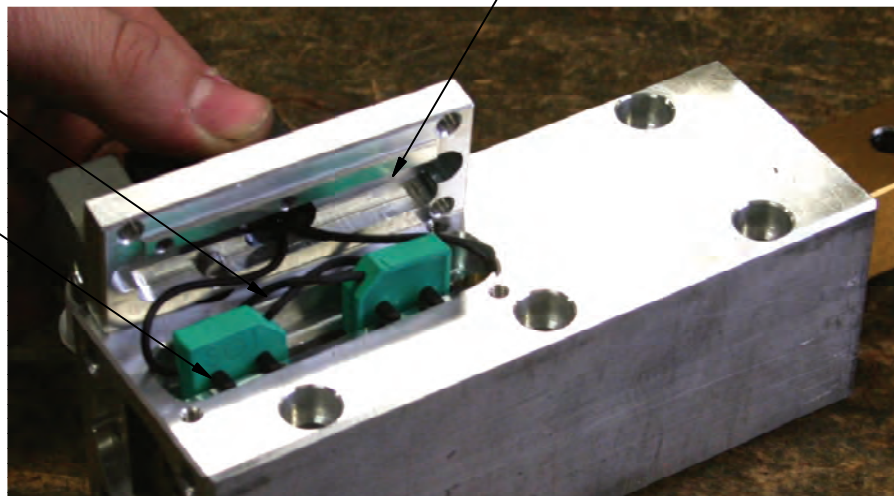

RAM WIPER MAINTENANCE

Welker recommends annual changing of urethane wiper. Wipers are maintenance items and are not covered under standard product warranty. Steam cleaning or wiping contamination off during the course of normal machine maintenance is desirable.

1. Disengage plant air from unit. Remove tooling from unit ram.
2. Remove shroud screws. Remove shroud.
3. Remove wiper screws. Remove wiper retainer (SB4 only). Remove wiper.
4. Clean ram, removing residual debris.
5. Install new wiper using Tribolube-18 or similar synthetic hydrocarbon grease.
6. Replace wiper retainer (SB4 only).
7. Install wiper screws.
8. Install shroud with shroud screws.
9. Install tooling on unit ram.
10. Engage plant air, making sure lines are free of contaminants.

SB4, SB6

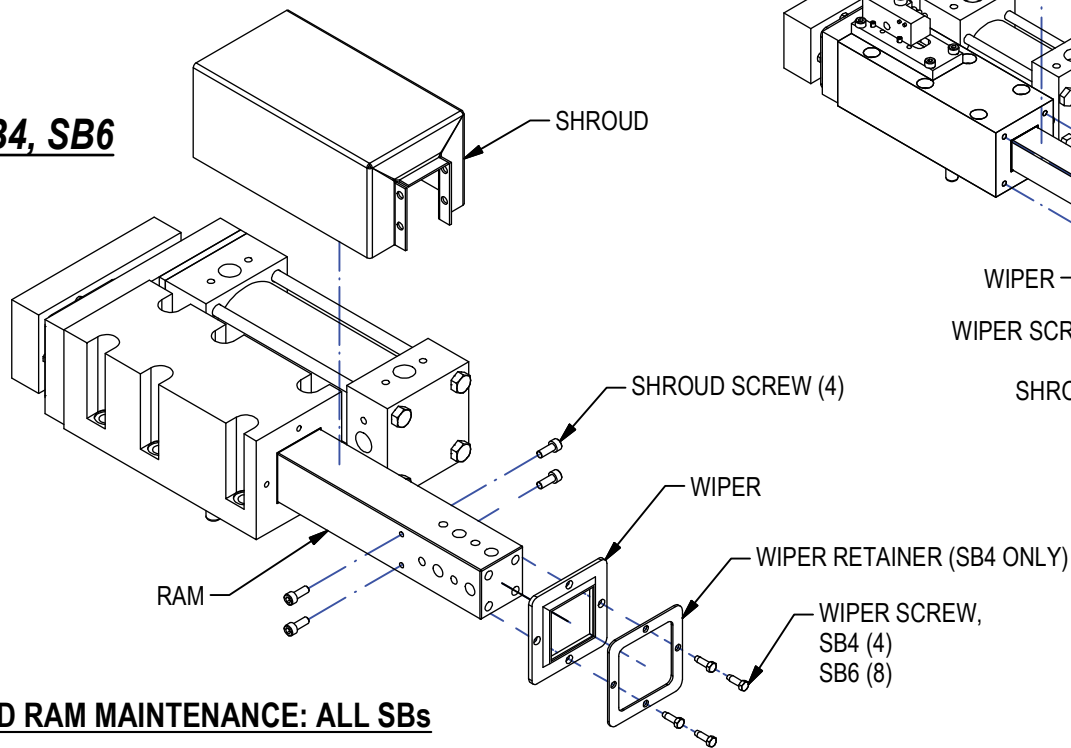

SB2

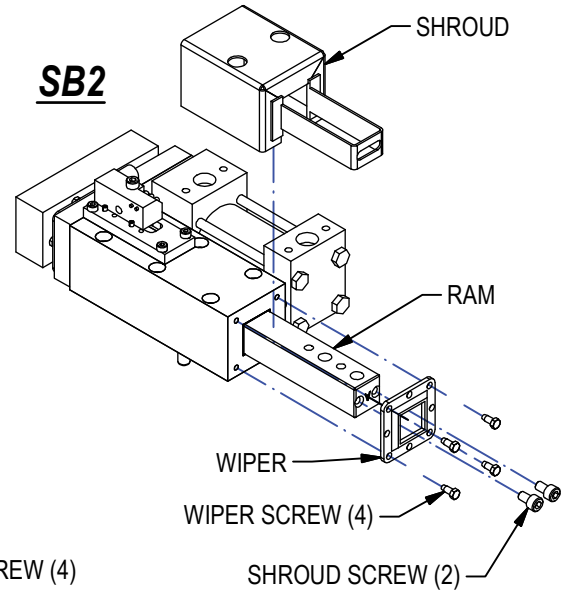

END RAM MAINTENANCE: ALL SBs

1. Disengage plant air from unit. Remove ram screw securing ram to tie bar.
2. Pull ram out of pocket in tie bar.
3. Remove tie bar, sliding to side to disengage from coupler. Note placement of rigid adapter if present.
4. Remove wiper screws. Remove wiper retainer (SB4 only). Remove wiper.
5. Clean ram, removing residual debris.
6. Install new wiper using Tribolube-18 or similar synthetic hydrocarbon grease.
7. Replace wiper retainer (SB4 only). Install wiper screws.
8. Engage tie bar with coupler.
9. Insert ram into pocket in the tie bar and secure with screw.
10. Engage plant air, making sure lines are free of contaminants.

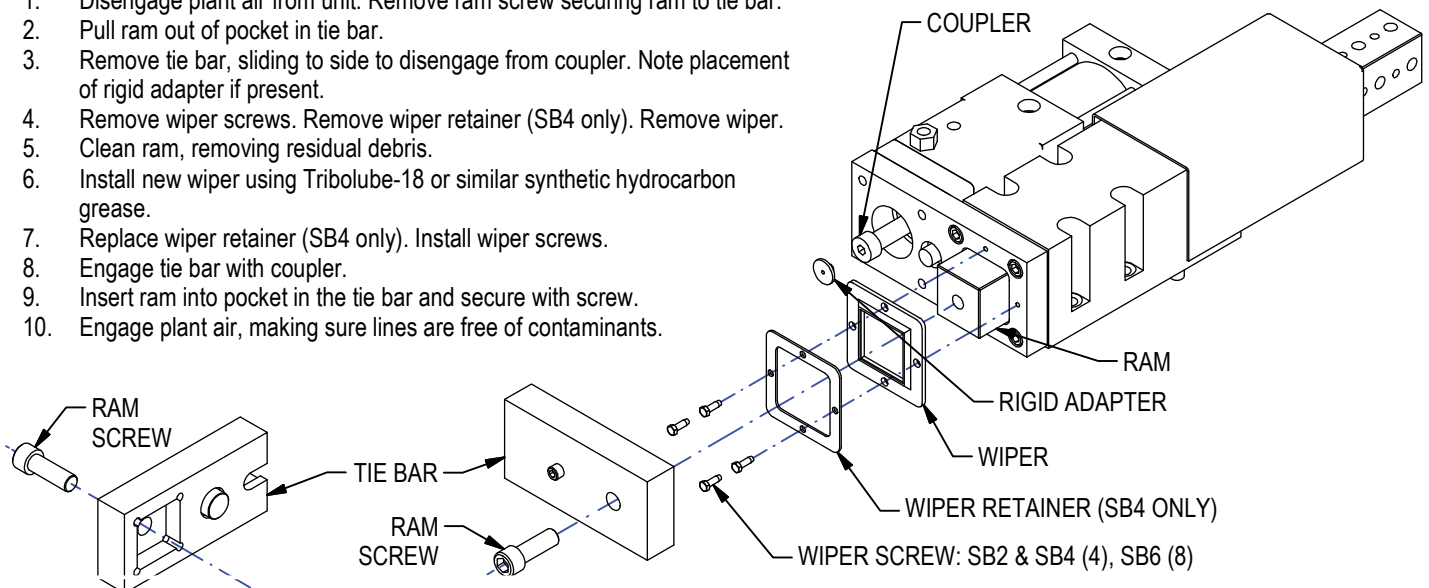

CYLINDER / SEAL MAINTENANCE

TO REMOVE/REPLACE OR ROTATE CYLINDER:

1. Remove screw securing ram to tie bar.
2. Pull ram out of pocket in tie bar.
3. Remove tie bar, sliding to side to disengage from coupler. Note placement of rigid adapter if present.
4. Loosen cylinder tie rods completely.
5. Hold cylinder in one hand.
6. Remove cylinder. **KEEP CYLINDER ASSEMBLED**
7. Replace cylinder or rotate cylinder to desired orientation.
8. Secure tie rods evenly. Tighten in an "X" pattern to torque specifications.
9. Engage tie bar with coupler.
10. Insert ram into pocket in the tie bar and secure with screw.
11. Check for leaks.

Tie Rod Torque Specifications				
Shot Pin Series	Thread	ft-lbf	in-ibf	N-m
24	1/4-28"	6.5	78	8.8
40	5/16-24"	12	144	16.3
60	3/8-24"	22	264	29.8

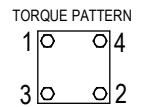

TO REPLACE CYLINDER SEALS:

1. Remove cylinder following steps above.
2. Remove end caps from tube. Clean seal grooves thoroughly.
Replace tube seals.
3. Remove piston seals using plastic or brass tool.
NOTE ORIENTATION OF SEALS. Inspect parts for wear. Clean piston and install new seals.
4. Lightly coat the piston seals and tube I.D. with Acrolube grease.
5. Remove the coupler from cylinder rod using gentle heat, being careful not to melt seals. Remove rod cartridge.

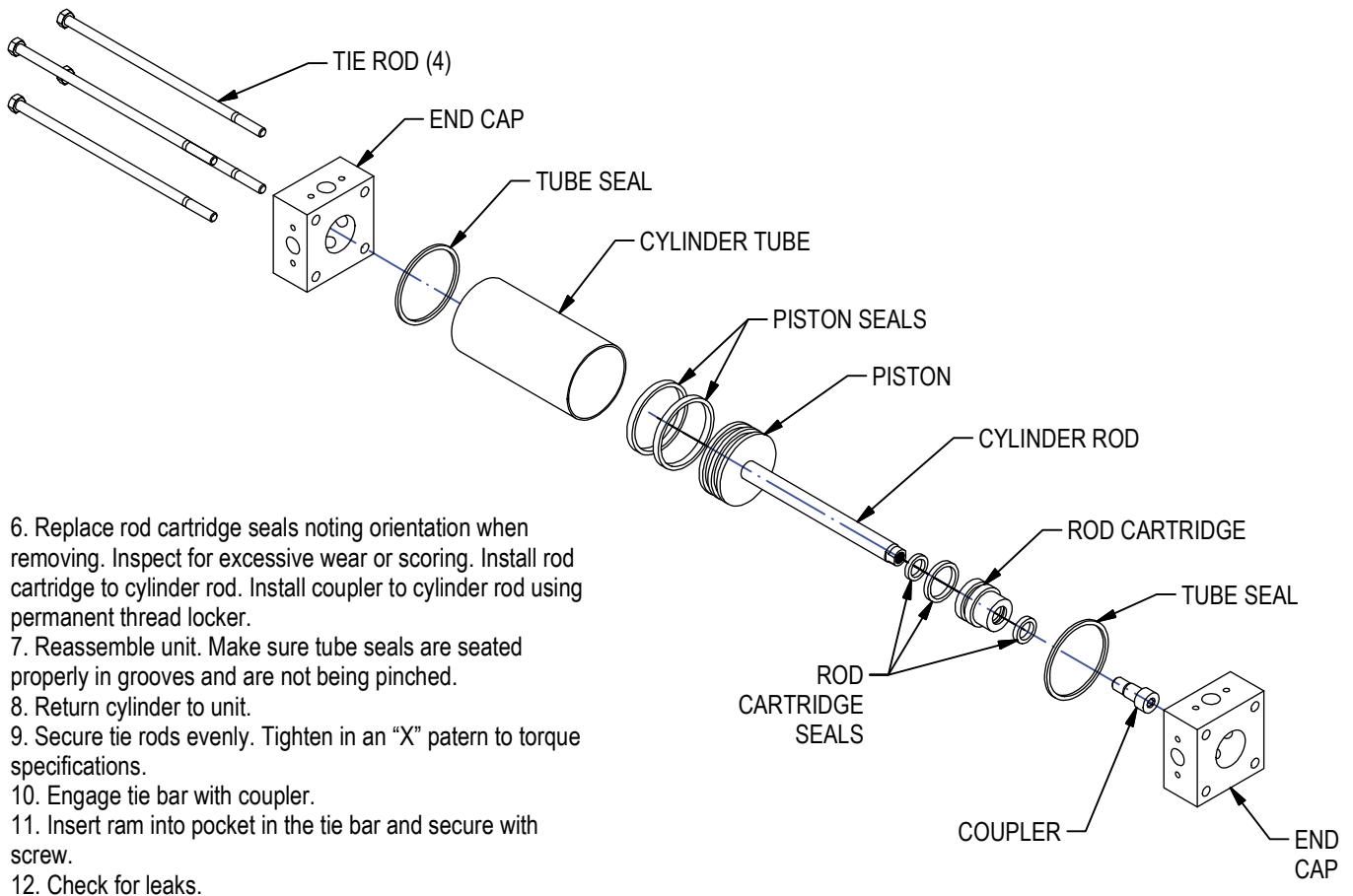
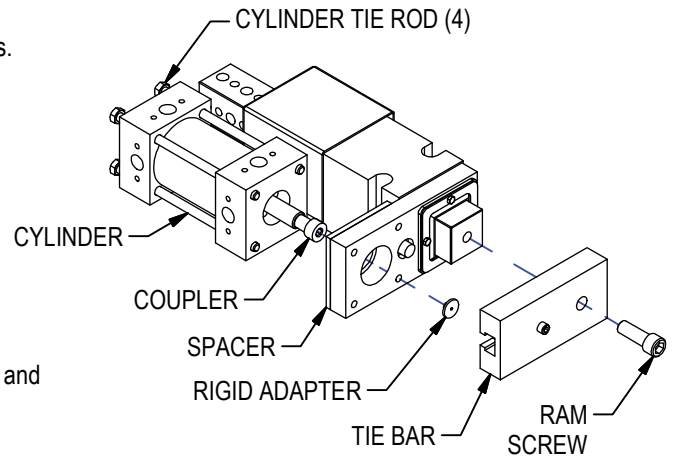

6. Replace rod cartridge seals noting orientation when removing. Inspect for excessive wear or scoring. Install rod cartridge to cylinder rod. Install coupler to cylinder rod using permanent thread locker.
7. Reassemble unit. Make sure tube seals are seated properly in grooves and are not being pinched.
8. Return cylinder to unit.
9. Secure tie rods evenly. Tighten in an "X" pattern to torque specifications.
10. Engage tie bar with coupler.
11. Insert ram into pocket in the tie bar and secure with screw.
12. Check for leaks.