

RMP RETRACTING MICRO PIN

CAN BE USED WITHOUT BACKUP. NO PIN MODIFICATION BELOW PIN SHOULDER

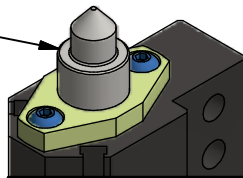

NO SEALS IN BACKUP. BACKUP CAN BE MACHINED AWAY FOR CLEARANCE

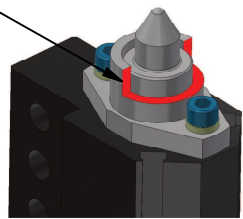

- CUSTOMER-REPLACEABLE PIN
- ROUND PINS ONLY, NO ANTI-ROTATE
- 6mm PIN ENGAGEMENT, 15mm STROKE
- RAP COUPLER

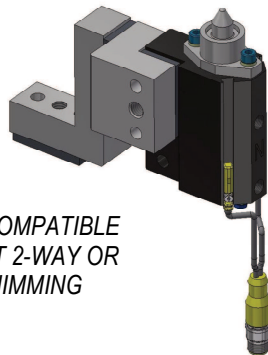
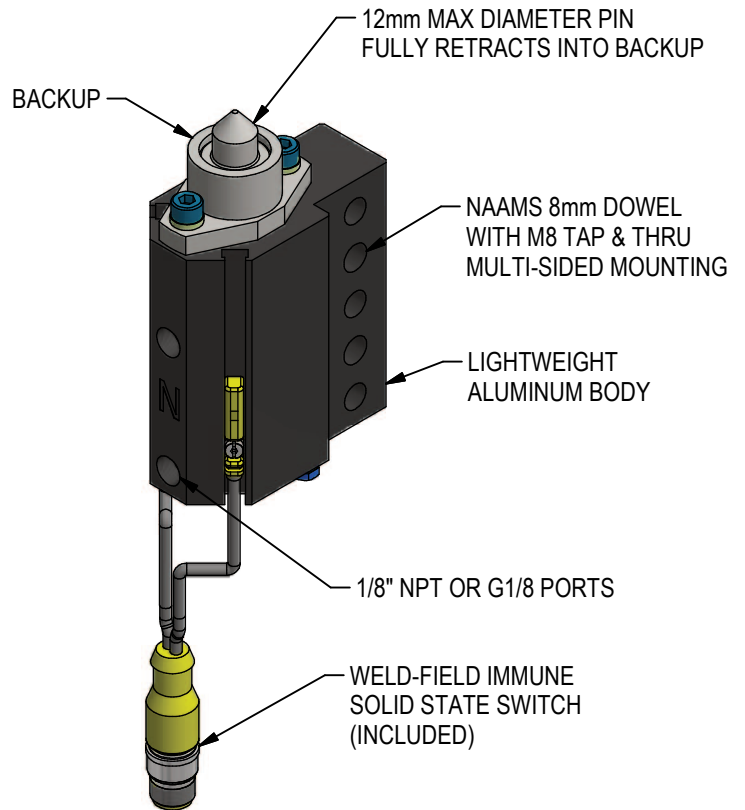

NAAMS COMPATIBLE
COMPACT 2-WAY OR
3-WAY SHIMMING

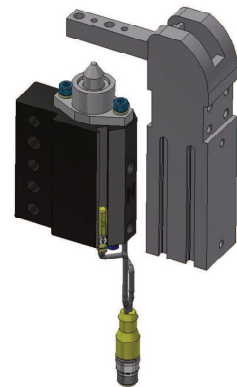

CLAMPING
BACKUP

RELEASED 8/28/18

ORDERING INFORMATION

R M P L 3

Pin Diameter _____

XXXX Pin Diameter (i.e. 8.00mm Pin = 0800)
(3.00mm-12.00mm Diameter Range)

WELKER
L3 SWITCH
INCLUDED

Backup _____

- X No Backup
- B With Backup

Actuator _____

- N NPT port cylinder
- G G Port Cylinder

REPLACEMENT PIN KIT ORDERING

KIT INCLUDES PIN, WIPER, INNER SEAL, PISTON SEAL, AND PLUG SEAL

R M P - R B K

Pin Diameter _____

XXXX Pin Diameter
3.00 - 12.00mm
Example:
8.00mm = 0800

APPLICATIONS

Retracting Micro Pins are for small, lightweight parts with minimal side load.

Buyoffs must include hole size and tolerance. No flow controls required or recommended.

Good applications:

- Metal ≤ 1.5 mm thick
- Vertical applications with small parts, pin pointing up
- Multiple metal with one hole being 2-way or clearance
- End effectors: closures, door, hood, deck lid, seating lines
- Non-automotive industries
- Load to extended pin, not a repositioning device

Bad applications:

- Multiple metal with same hole size
- Vertical applications with pin pointing down
- Horizontal applications with heavy parts or where the pinned part becomes part of heavy assembly
- Applications that will produce side loads >20 lbf on pin

(DO NOT SCALE DRAWING)

WELKER
ENGINEERED PRODUCTS
800-229-0890 www.welkerproducts.com

SHOWN WITH
BACKUP

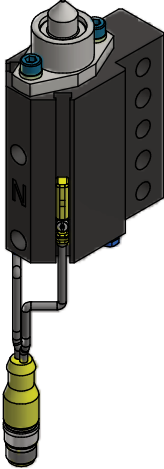

GENERAL DIMENSIONS

DESIGNER'S NOTE: SHIMMING
RECOMMENDED FOR X, Y, AND Z

NO BACKUP,
WITH PLATE

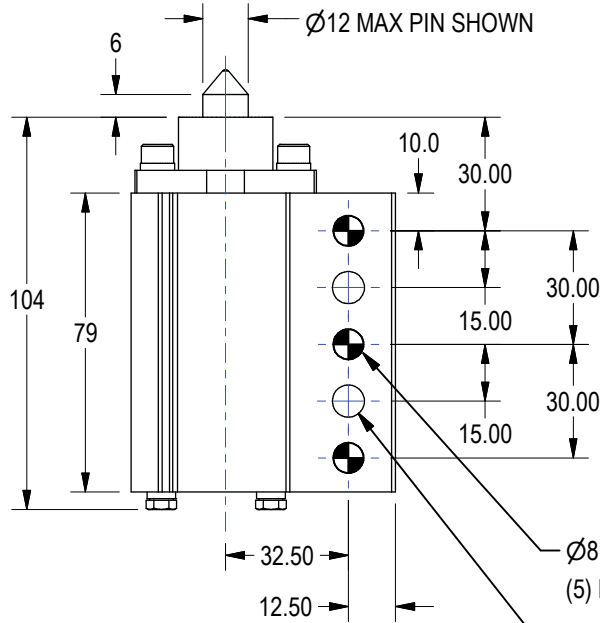
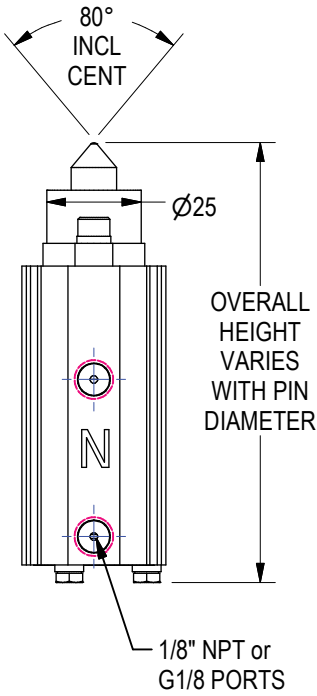
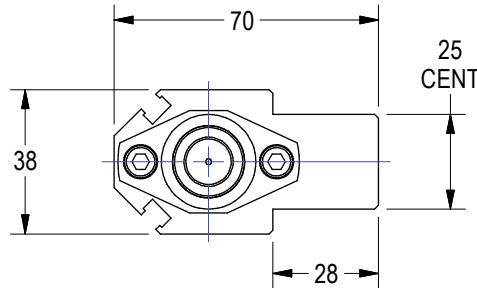
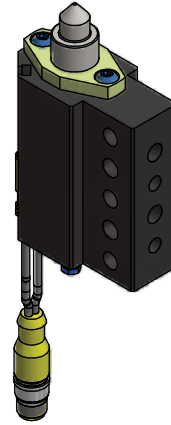

THIS VIEW:
NO BACKUP,
WITH PLATE

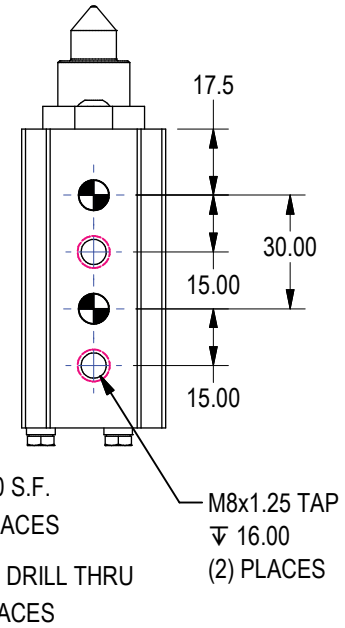

UNIT WEIGHT: 1.3 LBS

(DO NOT SCALE DRAWING)

WELKER
ENGINEERED PRODUCTS
800-229-0890 www.welkerproducts.com

PIN & SEAL REPLACEMENT

1. DISCONNECT AIR LINES TO UNIT.
2. REMOVE M4 SCREWS & LOCK WASHERS SECURING PLUG TO UNIT BODY.
3. REMOVE PLUG.
4. BACK PIN AND PISTON OUT OF UNIT AND REMOVE.
5. SLIDE PIN OUT FROM SLOT IN PISTON.
6. REPLACE PLUG SEAL & PISTON SEAL, APPLYING MAGNALUBE OR EQUIVALENT.
7. REMOVE M5 BACKUP SCREWS & LOCKWASHERS. REMOVE BACKUP, IF PRESENT.
8. REMOVE WIPER, NOTING ORIENTATION. REMOVE INNER SEAL.
9. APPLY MAGNALUBE OR EQUIVALENT TO PISTON, PIN, SEALS AND BODY BORE.
10. INSTALL NEW SEAL, WIPER. INSTALL NEW PIN TO SLOT IN PISTON.
11. REASSEMBLE UNIT.
12. APPLY REMOVEABLE THREAD ADHESIVE TO SCREWS. TORQUE TO SHOWN.

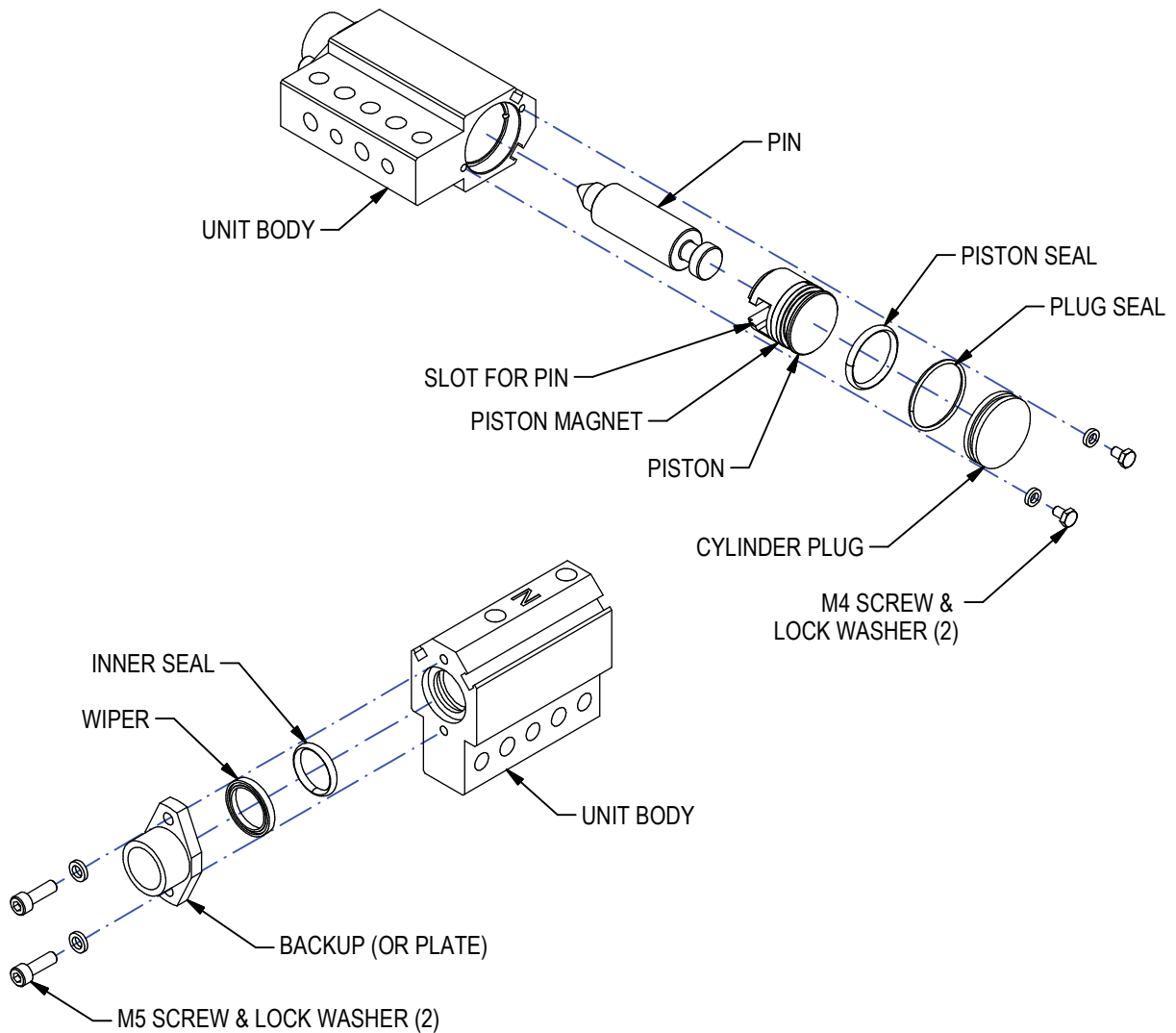

Tightening Torques for Metric Bolts (installed dry)

	Steel		Aluminum	
	Nm	ft lb.	Nm	ft lb.
M4	5 Nm	4 ft lb.	2.5 Nm	2 ft lb.
M5	10 Nm	7.375 ft lb.	5 Nm	3.6875 ft lb.
M6	19 Nm	14.014 ft lb.	9.5 Nm	7.007 ft lb.
M8	45 Nm	33.19 ft lb.	22.5 Nm	16.595 ft lb.
M10	89 Nm	65.643 ft lb.	44.5 Nm	32.8215 ft lb.
M12	156 Nm	115.06 ft lb.	78 Nm	57.53 ft lb.

(DO NOT SCALE DRAWING)

WELKER
ENGINEERED PRODUCTS
800-229-0890 www.welkerproducts.com