

Patent #6,786,478

PCZ SERIES PIN CLAMPS

FOR POSITIVE LOCATING AND CLAMPING

UP TO 2mm PART THICKNESSES

8.00 to 16.00mm PIN DIAMETERS

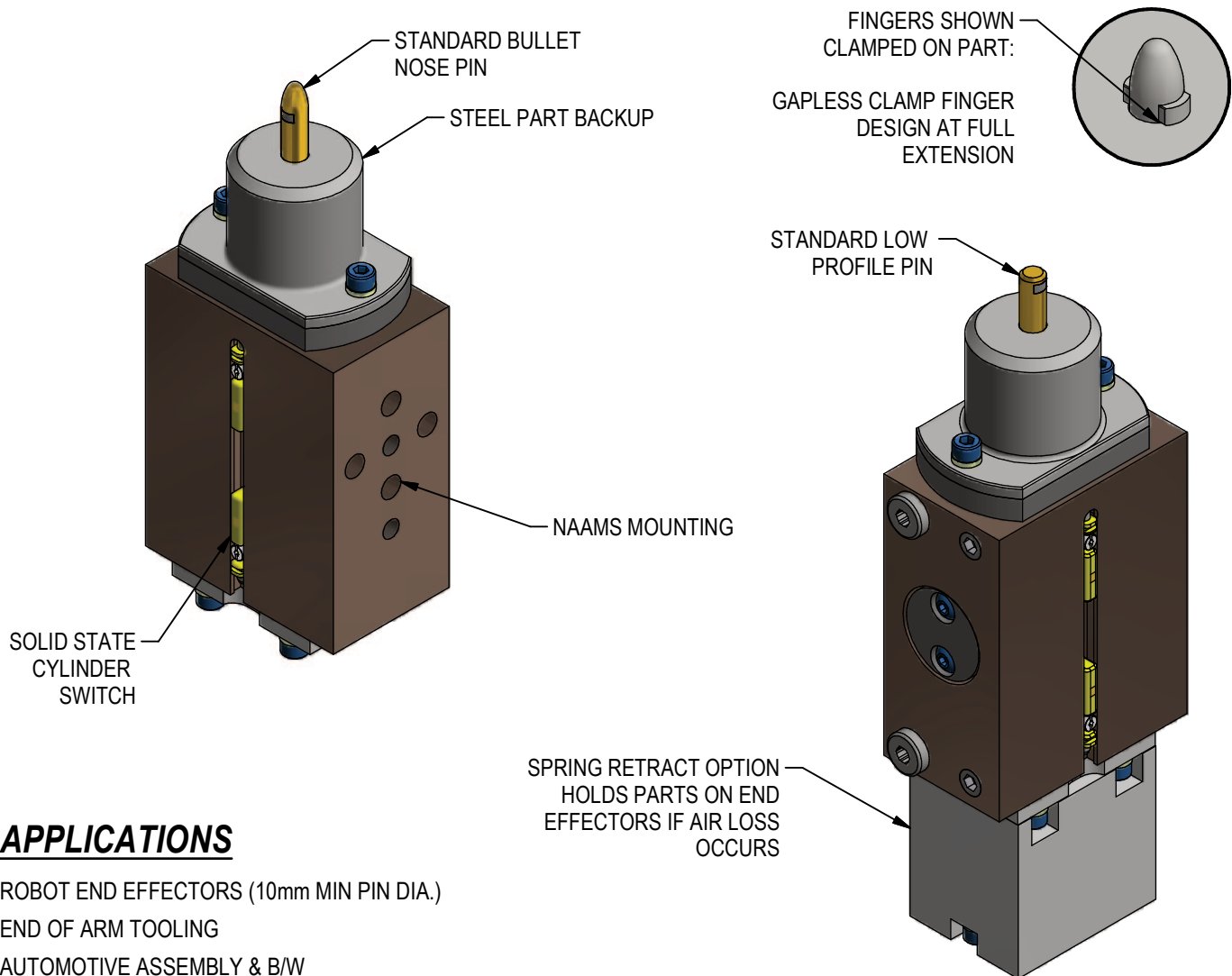

APPLICATIONS

ROBOT END EFFECTORS (10mm MIN PIN DIA.)
END OF ARM TOOLING
AUTOMOTIVE ASSEMBLY & B/W
PALLETIZED PART LOCATE & TRANSFER
WELDING & HIGHLY CORROSIVE ENVIRONMENTS

RELEASED 2/26/18

PIN CLAMP WORKSHEET

Project	Station #	Date	
Customer	Contact	Email	Phone

NOMINAL HOLE DIAMETER: _____ Tolerance ± _____

Single Metal Thickness: _____ Part print attached

Multiple Metal Quantity: _____ Overall thickness: _____

Will the pin be in geo holes in multiple metal pieces? Yes No

RECOMMENDED PIN DIAMETER:

Series	Application	Pin sizing
PCZ	geo	0.2mm under minimum
PCZ	material handling	0.5mm under minimum
PCS, PCM, PCT, PCY	geo	0.15mm under minimum
PCS, PCM, PCT, PCY	material handling	0.5mm under minimum

FINGER & PIN CLAMP ORIENTATION

Pin clamp mounted horizontally:

Pin clamp mounted inverted or vertically:

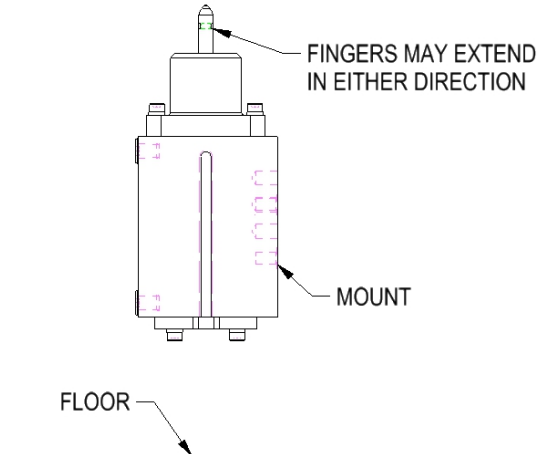
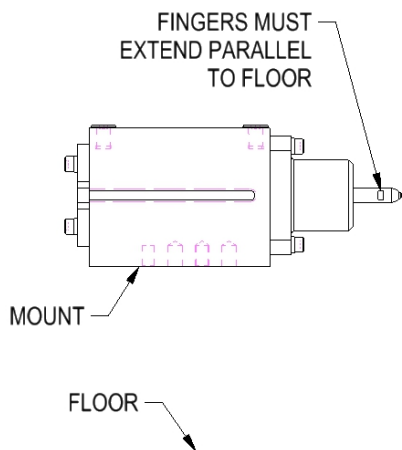

Part # _____	Mounting	<input type="checkbox"/> Horizontal	<input type="checkbox"/> Vertical or inverted
	Fingers	<input type="checkbox"/> @ 0°	<input type="checkbox"/> @ 90°
Part # _____	Mounting	<input type="checkbox"/> Horizontal	<input type="checkbox"/> Vertical or inverted
	Fingers	<input type="checkbox"/> @ 0°	<input type="checkbox"/> @ 90°
Part # _____	Mounting	<input type="checkbox"/> Horizontal	<input type="checkbox"/> Vertical or inverted
	Fingers	<input type="checkbox"/> @ 0°	<input type="checkbox"/> @ 90°

ORDERING INFORMATION

NOTE: ALL BOXES MUST BE FILLED IN FOR A COMPLETE PART NUMBER



Pin Diameter
08.00 - 16.00mm to 2 Decimal Places

Pin Type
A Bullet Nose Pin with fingers at 0°
B Bullet Nose Pin with fingers at 90°
E Low Profile Pin with fingers at 0°
F Low Profile Pin with fingers at 90°

Actuator
A Double Acting
B Double Acting with Spring

Back Up Diameter
035 35mm Dia Max

Magnetic Solid State Switch
00 None
LX See Switch Chart

Port Type
A NPT
J G

Welker Cylinder Switch Chart

Option	QTY	Switch Part #	Wire	Output	Mfg
L3	1	SWITCH L3** Dual sensor, single connector switch: 1 switch required per cylinder	4	PNP	Welker
L5	2	MK5113 Single sensor, single connector switch: 2 switches required per cylinder	3	NPN	ifm Efactor

**L3 switch is weld field immune, comparable to World Switches

Standard Switch Option - All other options may affect price and delivery

All switches are DC M12 X 1, Quick Disconnect

TO ORDER REPLACEMENT CARTRIDGE



Pin Diameter
8.00 - 16.00 to 2 Decimal Places

Pin Type
A Bullet Nose Pin with fingers at 0°(Shown)
B Bullet Nose Pin with fingers at 90°
E Low Profile Pin with fingers at 0°
F Low Profile Pin with fingers at 90°

Actuator
A Dbl Acting
B Dbl Acting w Spring
R Dbl Acting w Retractable Pin (Ports @ 90deg)
S Dbl Acting w Retractable Pin (Ports @ 0deg)
T Dbl Acting w Retractable Pin & Spring (Ports @ 0deg)
U Dbl Acting w Retractable Pin & Spring (Ports @ 90deg)

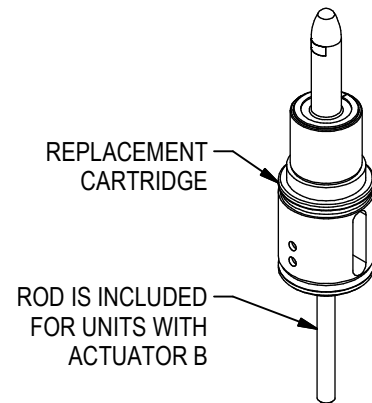

(DO NOT SCALE DRAWING)



GENERAL DIMENSIONS



WELKER PIN CLAMP
WEB PAGE

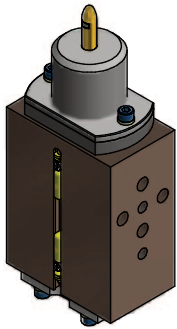

FINGERS EXTENDED IN
CLAMPED POSITION.
DIM = PIN DIA + 2.4mm

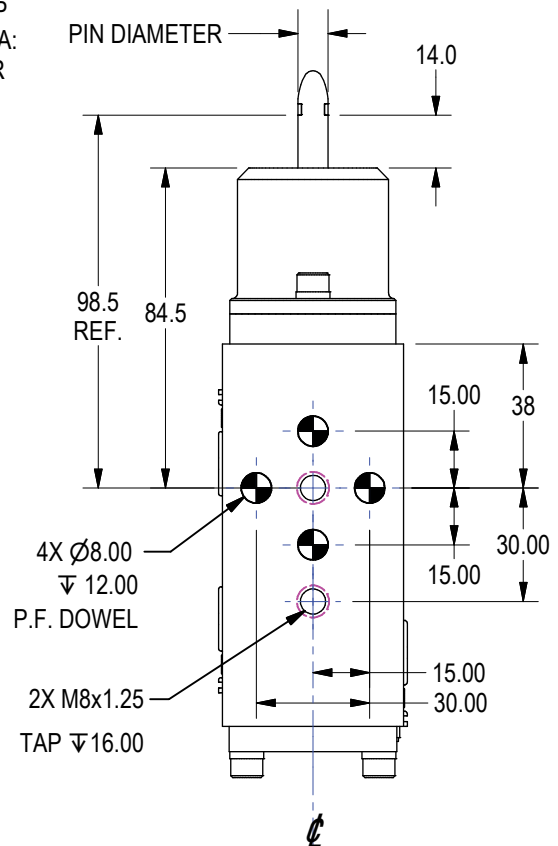
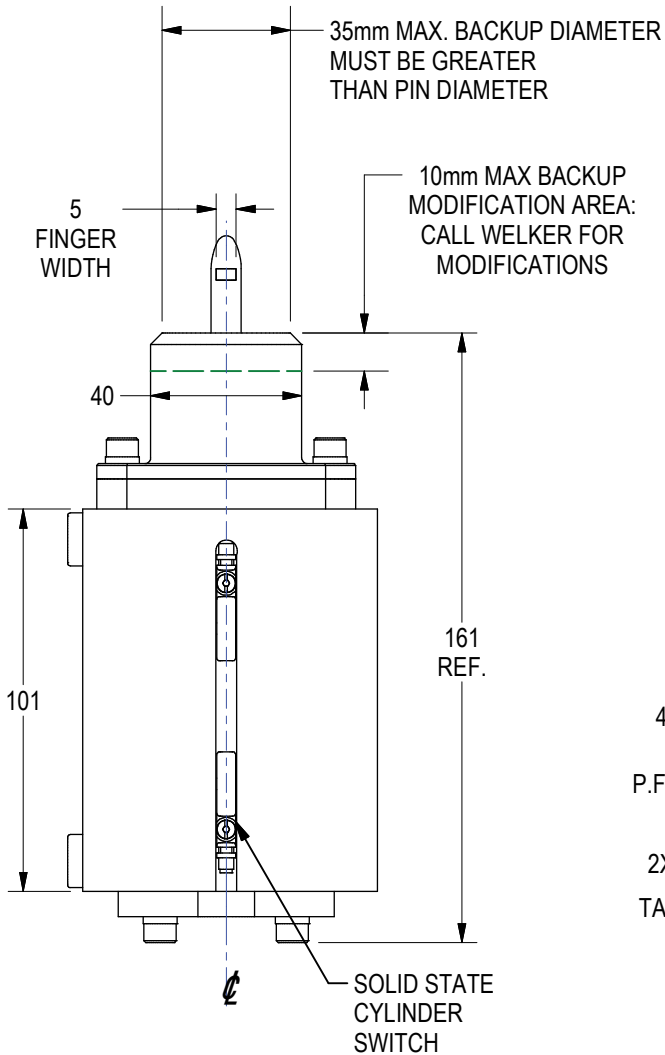
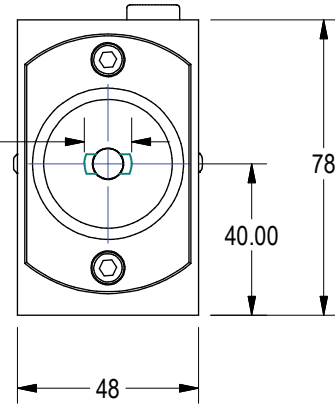

UNIT WEIGHT: 3.5 lbs
(WEIGHT VARIES WITH UNIT OPTIONS)

(DO NOT SCALE DRAWING)

WELKER
ENGINEERED PRODUCTS
800-229-0890 www.welkerproducts.com

LOCATING PIN OPTIONS

Z

A
A
0
0
0
3
5
K
B

Pin Diameter
08.00 - 16.00mm to 2 Decimal Places

Pin Type
A Bullet Nose Pin with fingers at 0°
B Bullet Nose Pin with fingers at 90°
E Low Profile Pin with fingers at 0°
F Low Profile Pin with fingers at 90°

PCZ PIN SIZING

To avoid part removal issues such as binding and pin breakage Welker recommends undersizing pin by 0.25mm

Part hole diameter: _____

Part weight: _____

Pin size: _____

NOTE: FOR HORIZONTAL APPLICATIONS, ORIENTATION OF THE CLAMP FINGER MOVEMENT SHOULD BE PARALLEL TO THE GROUND

PIN TYPE OPTION "A"
BULLET NOSE PIN WITH FINGERS SHOWN AT 0°
FINGERS EXTEND & RETRACT **PARALLEL** TO MOUNTING SURFACE

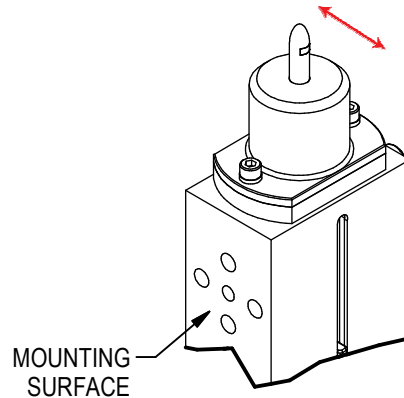

OPTION

- A** BULLET NOSE PIN WITH FINGERS AT 0°
- B** BULLET NOSE PIN WITH FINGERS AT 90°

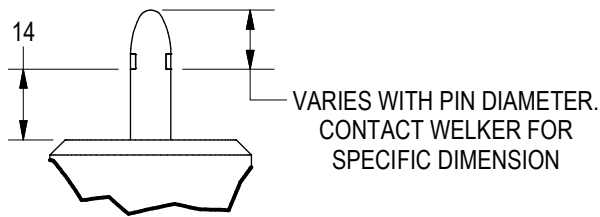

PIN TYPE OPTION "F"
LOW PROFILE PIN WITH FINGERS SHOWN AT 90°
FINGERS EXTEND & RETRACT **PERPENDICULAR** TO MOUNTING SURFACE

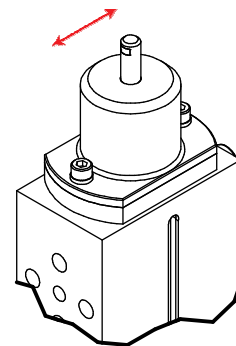

OPTION

- E** LOW PROFILE PIN WITH FINGERS AT 0°
- F** LOW PROFILE PIN WITH FINGERS AT 90°

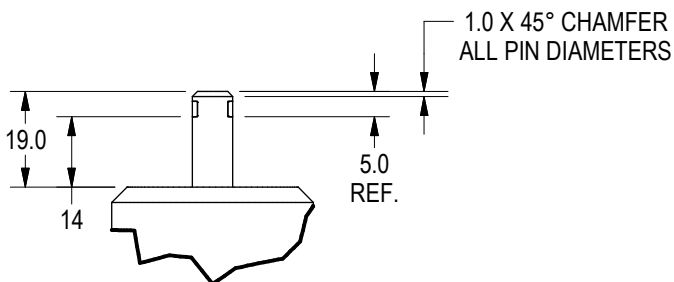

(DO NOT SCALE DRAWING)

WELKER
ENGINEERED PRODUCTS
800-229-0890 www.welkerproducts.com

ACTUATOR INFORMATION

Z
0
9
6
5
B

0
0
0
3
0
K
B

Actuator

- A** Double Acting
- B** Double Acting with Spring

Port Type

- A** NPT
- J** G

	CLAMP FORCE (LBS.) (INCLUDES SPRING PRESSURE)
DESCRIPTION	60 PSI
A DOUBLE ACTING	29
B DOUBLE ACTING WITH SPRING	39

NOTES:

AT LOSS OF AIR PRESSURE, SPRING ASSIST WILL MAINTAIN CONSTANT CLAMP PRESSURE: **10 LBF**

FOR INVERTED APPLICATIONS, PART WEIGHT MUST NOT EXCEED: **10 LBF**

NORMAL OPERATING TEMPERATURE FOR ALL ACTUATORS: **-10°F TO 165°F (-23°C TO 74°C)**

ACTUATOR A
DOUBLE ACTING

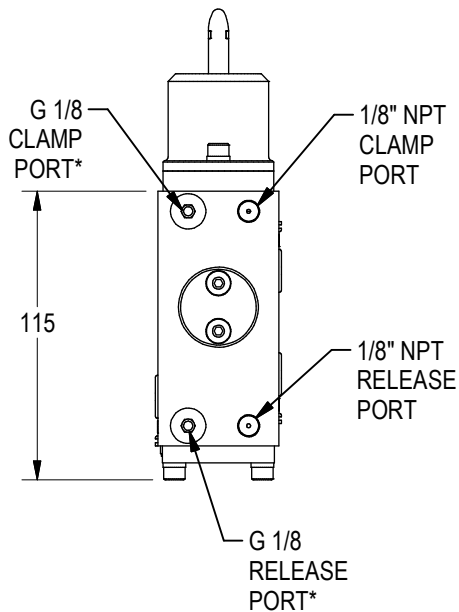

ACTUATOR B
NON RETRACTABLE SPRING CLAMP

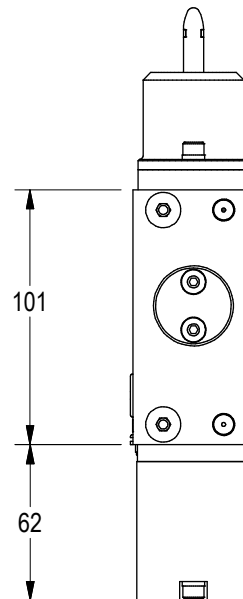

(DO NOT SCALE DRAWING)

ENGINEERED PRODUCTS

800-229-0890 www.welkerproducts.com

*SHOWN PLUGGED

PCZ PIN CLAMP DESIGN GUIDELINES

1. FOR HORIZONTAL APPLICATIONS, ORIENTATION OF THE CLAMP FINGER MOVEMENT SHOULD BE PARALLEL TO THE GROUND FOR ROUND HOLES. SEE GENERAL DIMENSION SHEET FOR MAXIMUM SIDE LOADS.
2. PROXIMITY OF SOME WELD APPLICATIONS TO THE PIN CLAMP COULD AFFECT THE LIFE OF THE PIN AND CLAMP FINGERS.
3. IMPACT LOADING AND EXCESSIVE SIDE LOADING MUST BE AVOIDED. FOR ROBOTICS AND HARD AUTOMATION APPLICATIONS, THE LOCATING PINS NEED TO ENGAGE AND DISENGAGE AT LOAD AND UNLOAD.
4. WELKER ENGINEERED PRODUCTS DOES NOT RECOMMEND MORE THAN ONE 4-WAY AND ONE 2-WAY LOCATING DEVICE IN A COMMON GEO SETTING APPLICATION. PIN BIND AND EXCESSIVE SIDE LOAD MAY RESULT. IF A GEO SETTING APPLICATION REQUIRES MULTIPLE LOCATING DEVICES, CONTACT WELKER.
5. PCZ PIN CLAMPS ARE DESIGNED TO BE OPERABLE UP TO **60 PSI MAX.**
6. PIN CLAMP PNEUMATIC ACTUATORS HAVE INTEGRATED FLOW RESTRICTIVE ORIFICES. FLOW CONTROLS ARE NOT REQUIRED.

WARRANTY

WELKER ENGINEERED PRODUCTS WARRANTS TO ITS CUSTOMERS PURCHASING PIN CLAMPS MANUFACTURED BY WELKER THAT THESE UNITS ARE FREE FROM DEFECTS IN WORKMANSHIP AND MATERIALS. WELKER WARRANTS IT WILL REPAIR DEFECTS IN ITS MANUFACTURE DETERMINED BY WELKER TO HAVE OCCURRED AS A RESULT OF DEFECTIVE WORKMANSHIP AND /OR MATERIALS. THIS WARRANTY AUTOMATICALLY EXPIRES AT THE EARLIER OF THREE YEARS FROM THE DATE OF WELKER BEARING'S SHIPMENT OF THE PRODUCTS TO ITS CUSTOMER, OR THREE MILLION CYCLES. THE AFOREMENTIONED WARRANTY SHALL NOT APPLY IF WELKER DETERMINES THE PIN CLAMP(S) WERE MISAPPLIED, ABUSED, OR MODIFIED BY THE CUSTOMER. WITH THE EXCEPTION OF THE THREE YEAR OR THREE MILLION CYCLE WARRANTY ON DEFECTIVE WORKMANSHIP AND MATERIALS, WELKER BEARING MAKES NO EXPRESS WARRANTY, NO WARRANTY OF MERCHANTABILITY, NO WARRANTY OF FITNESS FOR A PARTICULAR PURPOSE AND NO WARRANTY WHICH EXTENDS BEYOND THIS WRITING ON WELKER MANUFACTURED PIN CLAMPS SOLD BY WELKER BEARING.

LOCATING PINS AND CLAMP FINGERS ARE CONSIDERED WEAR ITEMS AND AS SUCH ARE NOT INCLUDED IN THIS WARRANTY UNLESS THERE IS A MANUFACTURING DEFECT AS STATED ABOVE.

UNDER NO CIRCUMSTANCES SHALL WELKER BEARING BE LIABLE TO ANYONE FOR INCIDENTAL, CONSEQUENTIAL, EXEMPLARY, SPECIAL OR PUNITIVE DAMAGES WHETHER DIRECT OR INDIRECT, INCLUDING, BUT NOT LIMITED TO DOWN TIME, ARISING OUT OF OR RELATED TO ANY PRODUCTS SOLD OR MANUFACTURED BY WELKER ENGINEERED PRODUCTS.

ANY PRODUCT THOUGHT TO BE DEFECTIVE IN WORKMANSHIP OR MATERIALS MUST BE RETURNED TO WELKER FREIGHT PREPAID FOR EVALUATION. WELKER SHALL NOT BE LIABLE FOR LABOR COST INCURRED IN THE REMOVAL OF A PART, DEFECTIVE PART OR THE INSTALLATION OF ANY REPLACEMENT PART.

(DO NOT SCALE DRAWING)

