

EXPANDING LOCATING PIN

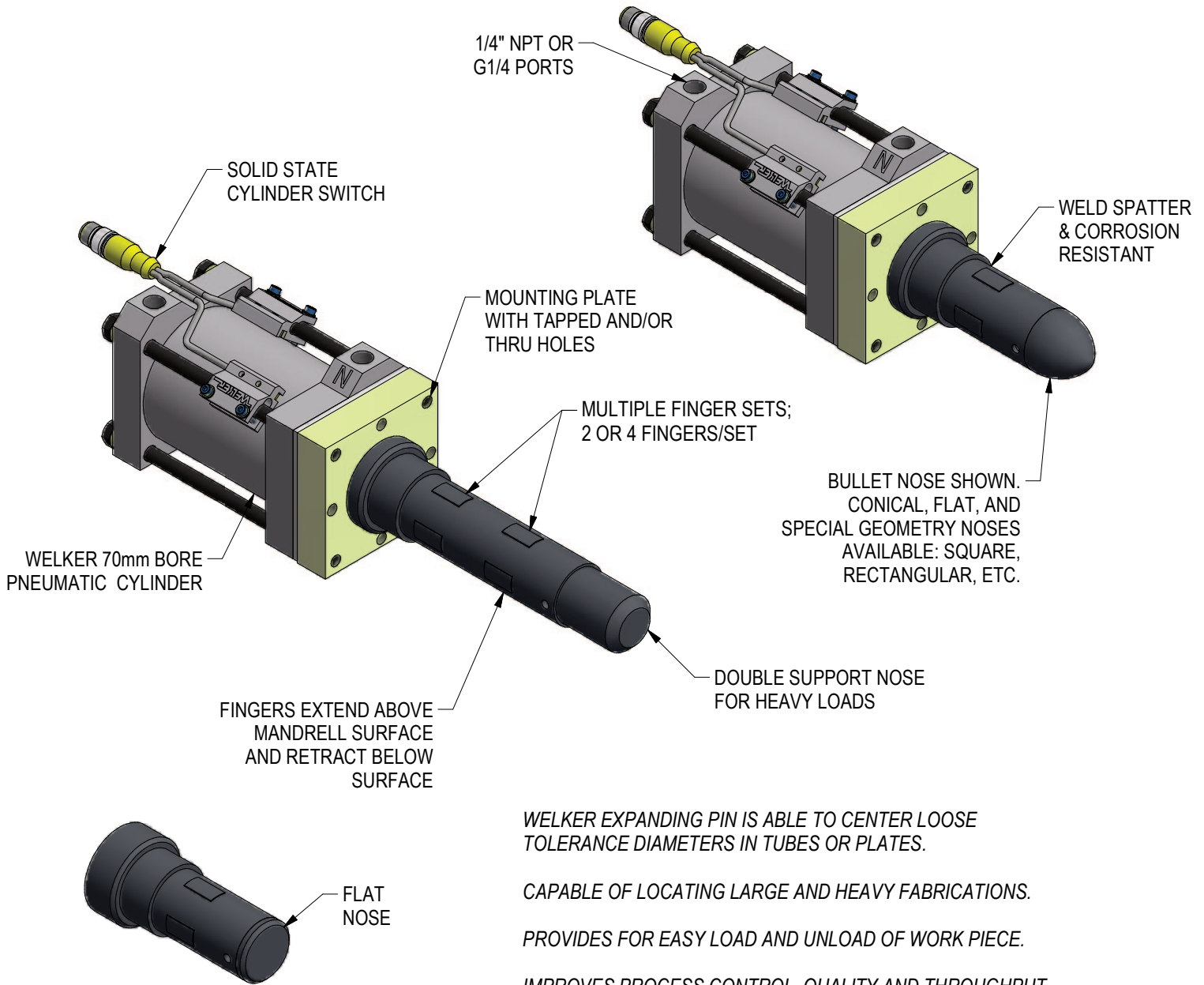

WELKER EXPANDING PIN IS ABLE TO CENTER LOOSE TOLERANCE DIAMETERS IN TUBES OR PLATES.

CAPABLE OF LOCATING LARGE AND HEAVY FABRICATIONS.

PROVIDES FOR EASY LOAD AND UNLOAD OF WORK PIECE.

IMPROVES PROCESS CONTROL, QUALITY AND THROUGHPUT.

ENGINEERED TO SPECIFIC APPLICATION REQUIREMENTS.

EXPANDING PIN DESIGN STYLES

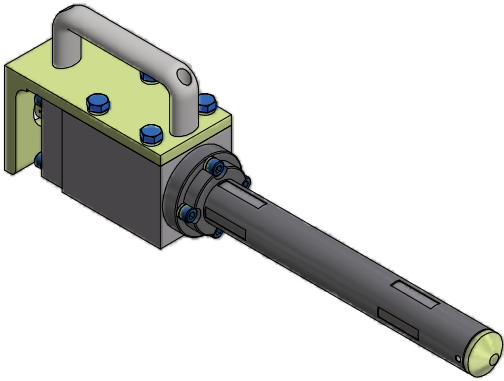

DOUBLE SET OF 4 FINGERS WITH HANDLE.
DRIVEN BY NUT RUNNER

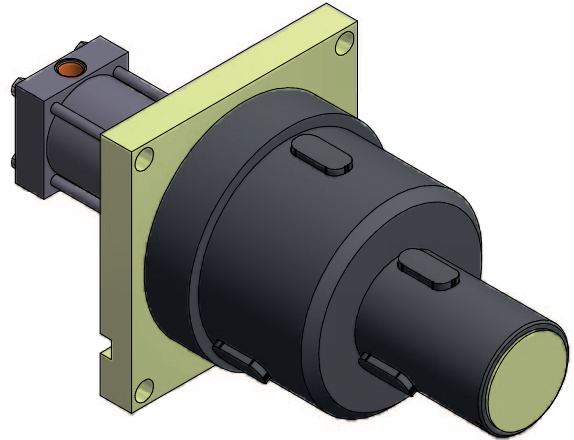

DUAL DIAMETER WITH 3 FINGERS EACH DIA
& HYDRAULIC CYLINDER

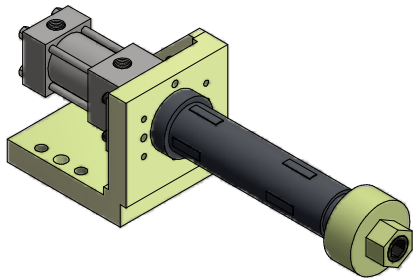

DOUBLE SET OF 4 FINGERS
WITH THREAD ON CLAMP
AND HYDRAULIC CYLINDER

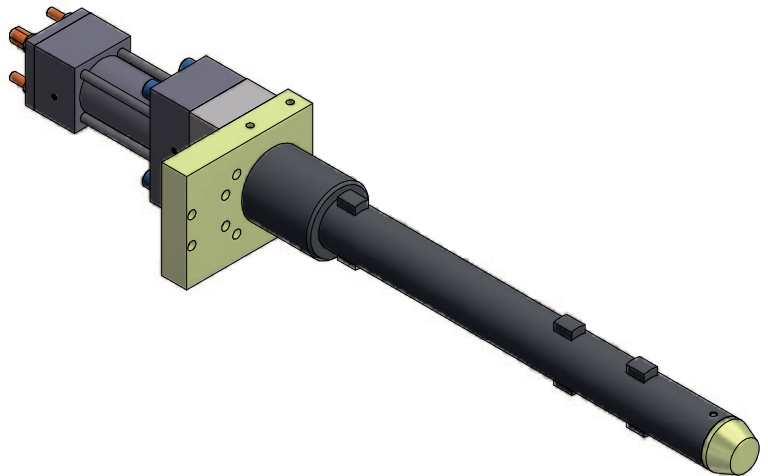

TRIPLE SET OF 2 FINGERS
WITH HYDRAULIC CYLINDER

(DO NOT SCALE DRAWING)

WELKER

ENGINEERED PRODUCTS

800-229-0890 www.welkerproducts.com

UNIT WITH SINGLE SET OF FINGERS

APPLICATION INFORMATION _____

 APPLICATION ORIENTATION _____
 MAXIMUM HOLE DIAMETER _____
 MINIMUM HOLE DIAMETER _____
 BUSHING LENGTH _____

DATE _____
 CUSTOMER _____
 PROJECT _____
 STATION _____
 UNIT _____
 MODEL/PART NUMBER ON STATION _____

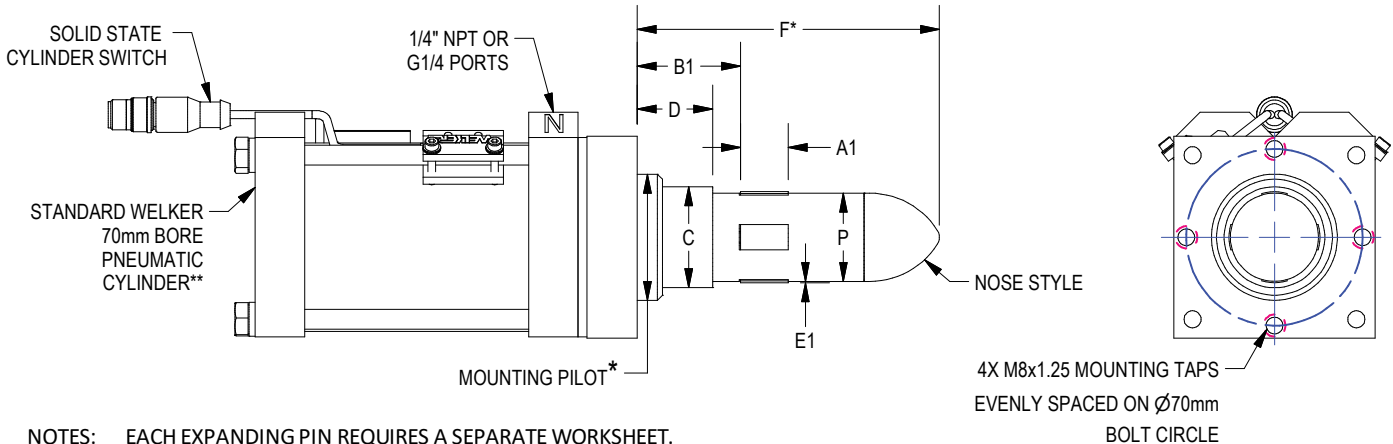

NOTES: EACH EXPANDING PIN REQUIRES A SEPARATE WORKSHEET.
 ORDER STANDARD EXPANDING PINS 1mm SMALLER THAN HOLE DIAMETER.
 EXAMPLE: 38mm HOLE, ORDER 37mm DIAMETER PIN

FINGER QUANTITY: _____ 2 OR 4
 A1: FINGER LENGTH _____ 20mm MINIMUM
 B1: FINGER LOCATION _____ 25mm MINIMUM
 C: HUB DIAMETER _____
 D: HUB LENGTH (OPTIONAL) _____
 E1: FINGER EXTENSION _____ 0.5mm PER SIDE IS STANDARD
 F: MAX. OAL OF PIN _____ LIST IF NECESSARY, FOR CLEARANCE CONDITIONS
 P: PIN DIAMETER _____
 NOSE STYLE: FLAT NOSE CONICAL NOSE BULLET NOSE
 DOUBLE SUPPORT NOSE (HEAVY LOADS)
 OTHER: _____
 CYLINDER TYPE: PNEUMATIC (AIR) HYDRAULIC**
 PORT TYPE: NPT G OTHER: _____
 SWITCH: _____ (SEE CHART BELOW)

* DIMENSION WILL VARY WITH PIN DIAMETER, FINGER LENGTH, FINGER EXTENSION

** HYDRAULIC CYLINDER AVAILABLE. MAX. PRESSURE 250 PSI CONTACT WELKER FOR INFORMATION

ADDITIONAL INFORMATION, SUCH AS SPECIAL ENVIRONMENTAL CONDITIONS, SPECIAL NOSE, HIGH LOAD/FORCE, ETC.

IS THIS A LONG CYCLE MIG OR EXTREME HEAT APPLICATION WHERE COOLING SHOULD BE CONSIDERED?

SELECT: YES / NO INTERNAL AIR COOLING OPTION? SELECT: YES / NO

Switch	Part Number	Mfr	Description
L3	SWITCH L3 L3 sw itch is w eld field immune, comparable to World Sw itches	Welker	4-Wire, 4-Pin, DC (PNP) M12 X 1 Quick Disconnect
L5	MK5113 (This is a single sensor sw itch: 2 sw itches are installed per cylinder)	ifm Efactor	3-Wire, 4-Pin, DC (NPN) M12 X 1 Quick Disconnect

Standard Switch Option - All other options may affect price and delivery

(DO NOT SCALE DRAWING)



ENGINEERED PRODUCTS

800-229-0890 www.welkerproducts.com

UNIT WITH DOUBLE SET OF FINGERS

APPLICATION INFORMATION _____

 APPLICATION ORIENTATION _____
 MAXIMUM HOLE DIAMETER _____
 MINIMUM HOLE DIAMETER _____
 BUSHING LENGTH _____

DATE _____
 CUSTOMER _____
 PROJECT _____
 STATION _____
 UNIT _____
 MODEL/PART NUMBER ON STATION _____

CAD MODEL OR SCREENSHOT REQUIRED WITH WORKSHEET

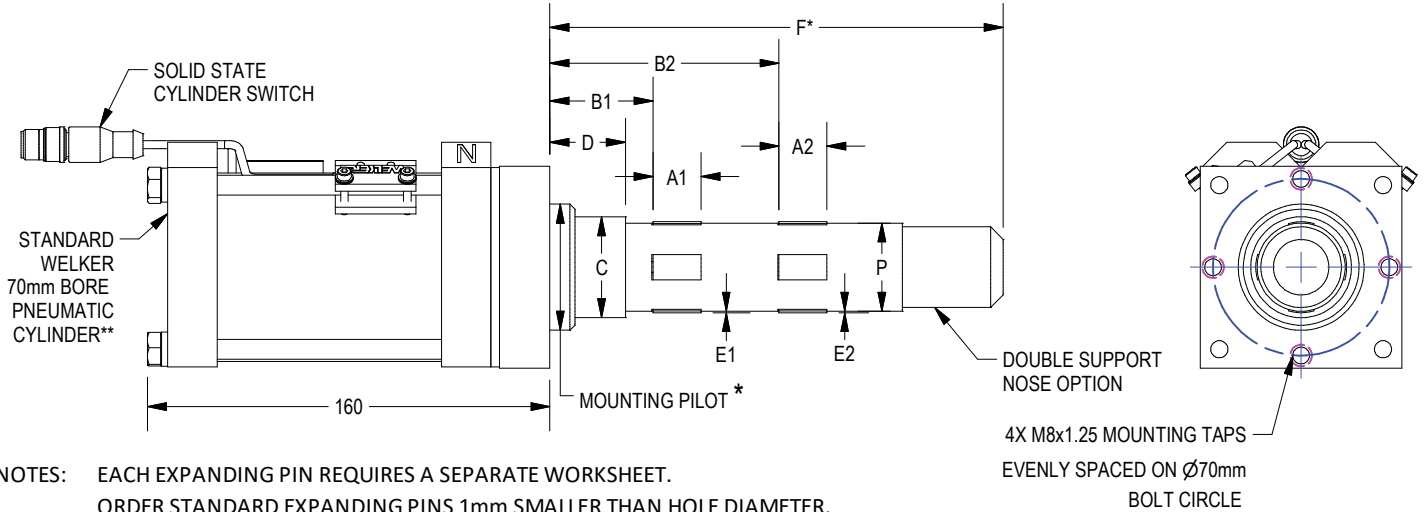

NOTES: EACH EXPANDING PIN REQUIRES A SEPARATE WORKSHEET.
 ORDER STANDARD EXPANDING PINS 1mm SMALLER THAN HOLE DIAMETER.
 EXAMPLE: 38mm HOLE, ORDER 37mm DIAMETER PIN

A1: FINGER QUANTITY _____ A2: FINGER QTY _____
 A1: FINGER LENGTH _____ A2: LENGTH _____ 20mm MINIMUM
 B1: FINGER LOCATION _____ B2: LOCATION _____ 25mm MINIMUM
 C: HUB DIAMETER _____
 D: HUB LENGTH (OPTIONAL) _____ 0.5mm PER SIDE
 E1: FINGER EXTENSION _____ E2: EXTENSION _____ IS STANDARD
 F: MAX OAL OF PIN _____ LIST IF NECESSARY, FOR CLEARANCE CONDITIONS
 P: PIN DIAMETER _____

NOSE STYLE: FLAT NOSE CONICAL NOSE BULLET NOSE
 DOUBLE SUPPORT NOSE (HEAVY LOADS)
 OTHER: _____

CYLINDER TYPE: PNEUMATIC (AIR) HYDRAULIC**

PORT TYPE: NPT G OTHER: _____

SWITCH: _____ (SEE CHART BELOW)

* DIMENSION WILL VARY WITH PIN DIAMETER, FINGER LENGTH, FINGER EXTENSION

** HYDRAULIC CYLINDER AVAILABLE. MAX. PRESSURE 250 PSI CONTACT WELKER FOR INFORMATION

ADDITIONAL INFORMATION, SUCH AS SPECIAL ENVIRONMENTAL CONDITIONS, SPECIAL NOSE, HIGH LOAD/FORCE, ETC.

IS THIS A LONG CYCLE MIG OR EXTREME HEAT APPLICATION WHERE AIR COOLING SHOULD BE CONSIDERED?

SELECT: YES / NO INTERNAL AIR COOLING OPTION? SELECT: YES / NO

Switch	Part Number	Mfr	Description
L3	SWITCH L3 L3 sw itch is w eld field immune, comparable to World Sw itches	Welker	4-Wire, 4-Pin, DC (PNP) M12 X 1 Quick Disconnect
L5	MK5113 (This is a single sensor sw itch: 2 sw itches are installed per cylinder)	ifm Efactor	3-Wire, 4-Pin, DC (NPN) M12 X 1 Quick Disconnect

Standard Switch Option - All other options may affect price and delivery

(DO NOT SCALE DRAWING)

WELKER
 ENGINEERED PRODUCTS
 800-229-0890 www.welkerproducts.com