

DB4 MAINTENANCE MANUAL

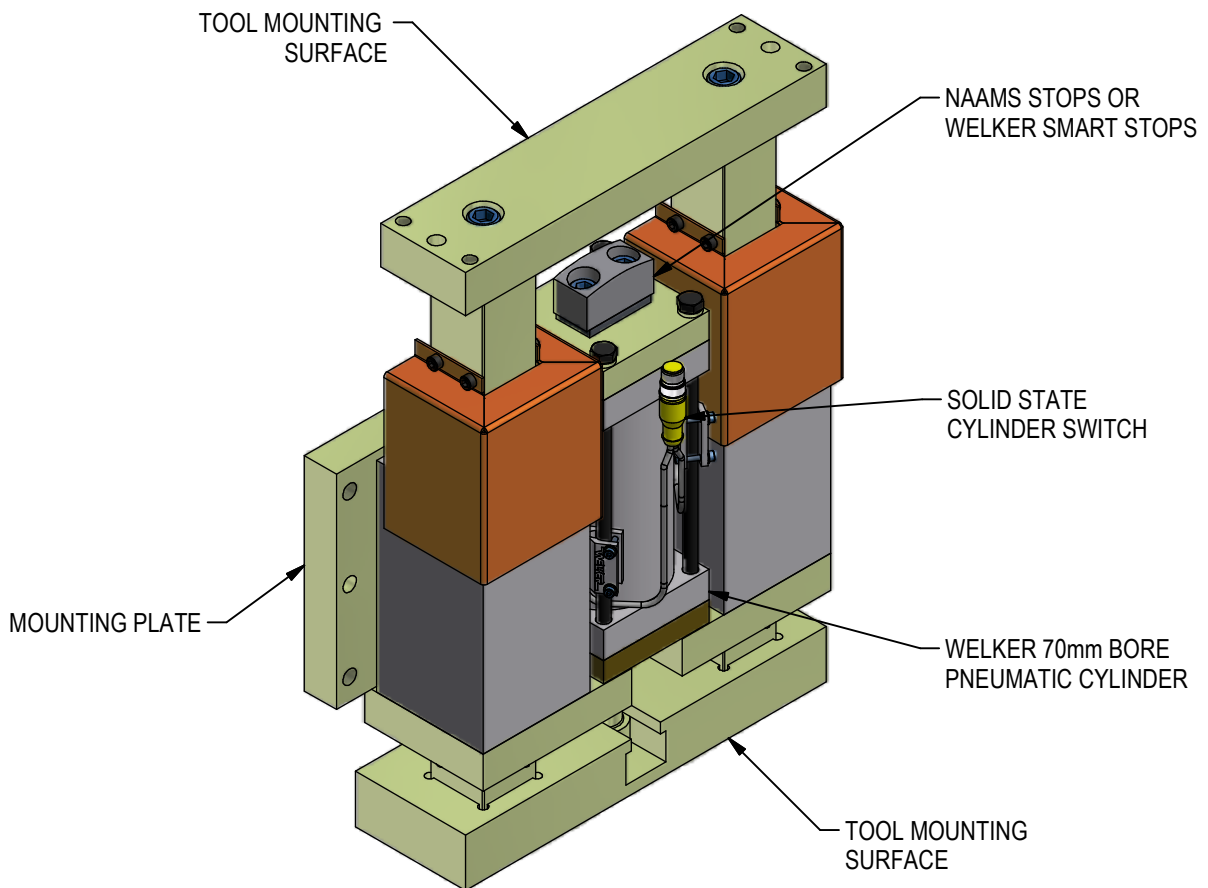

MAINTENANCE

SAFETY FIRST!

MAINTENANCE SHOULD ONLY BE PERFORMED BY QUALIFIED PERSONNEL. PROPER SAFETY GEAR AND PROCEDURES MUST BE USED AT ALL TIMES.

BEFORE PERFORMING MAINTENANCE, CUT OFF AIR SUPPLY TO THE UNIT, ENSURE THAT ALL AIR IS REMOVED AND THAT THERE ARE NO "TRAPPED AIR" CONDITIONS.

PREVENTATIVE MAINTENANCE: Regularly inspect unit to verify proper operation. Check for debris build up and clean as needed. Inspect all pneumatic, electrical, and mounting connections, making sure all connections are tight and secure.

CYLINDER: Welker pneumatic cylinders are lube free and require very little maintenance. Check for abnormal wear or damage. Plant air supply to the cylinder should be free of contaminants, filtered to a minimum of 50micron and have a water separator. Be sure fittings are in good condition. Seals are subject to wear under normal operating conditions. It is recommended to keep a spare cylinder seal kit on hand.

SWITCH: Switches may fail and need replacement; it is recommended to keep a spare switch on hand.

WIPER: Welker recommends annual changing of urethane wiper. Wipers are maintenance items and are not covered under standard product warranty.

TROUBLESHOOTING

FAILURE	POSSIBLE CAUSE	SOLUTION
Unit does not extend/retract.	Cylinder failure Switch failure	Inspect unit for dirt/debris. Check plant air supply for proper pressure; too little will result in lack of cylinder movement. Seals may be worn, damaged or deteriorating. Replace as needed. If cylinder has been serviced, be sure tie rod nuts have been tightened to torque specifications. Check switch for proper operation. Replace as needed.

REPLACEMENT PARTS

QTY	STOCK*	DESCRIPTION	PART NUMBER
4	4	DB4 WIPER	WIPER-40-KIT
	1	DB4 PNEUMATIC CYLINDER SEAL KIT	DB4-CSK
1	1	CYLINDER SWITCH	SEE CHART BELOW
2	1	WELKER SMART STOP	ASC020-PD

* RECOMMENDED SPARE PARTS TO KEEP IN STOCK

	Reorder #	Mfr. Part Number	Manufacturer	Description
Cylinder Switches	SWITCH L3	SWITCH L3 L3 switch is weld field immune, comparable to World Switches	Welker	4-Wire, 4-Pin, DC M12 X 1 (PNP) Quick Disconnect
	SWITCH L5	MK5113	ifm Efector	3-Wire, 4-Pin, DC M12 X 1 (NPN) Quick Disconnect

Standard Switch Option - All other options may affect price and delivery

RAM WIPER MAINTENANCE

Welker recommends annual changing of urethane wiper. Wipers are maintenance items and are not covered under standard product warranty. Steam cleaning or wiping contamination off during the course of normal machine maintenance is desirable.

NOTE: WIPERS ARE LOCATED ON BOTH ENDS OF UNIT RAM, 4 TOTAL

1. Disengage plant air from unit. Isolate unit from tooling.
2. Remove screws & lock washers from tie plate. Remove tie plate.
3. For wiper on shroud end: Remove shroud screws. Remove shroud.
4. Remove wiper screws. Remove wiper retainer. Remove wiper.
5. Clean ram, removing residual debris.
6. Install new wiper using Tribolube-18 or similar synthetic hydrocarbon grease.
7. Install new wiper retainer with wiper screws.
8. Install shroud with shroud screws.
9. Install tie plate to torque shown. Install unit to tooling.
10. Engage plant air, making sure lines are free of contaminants.

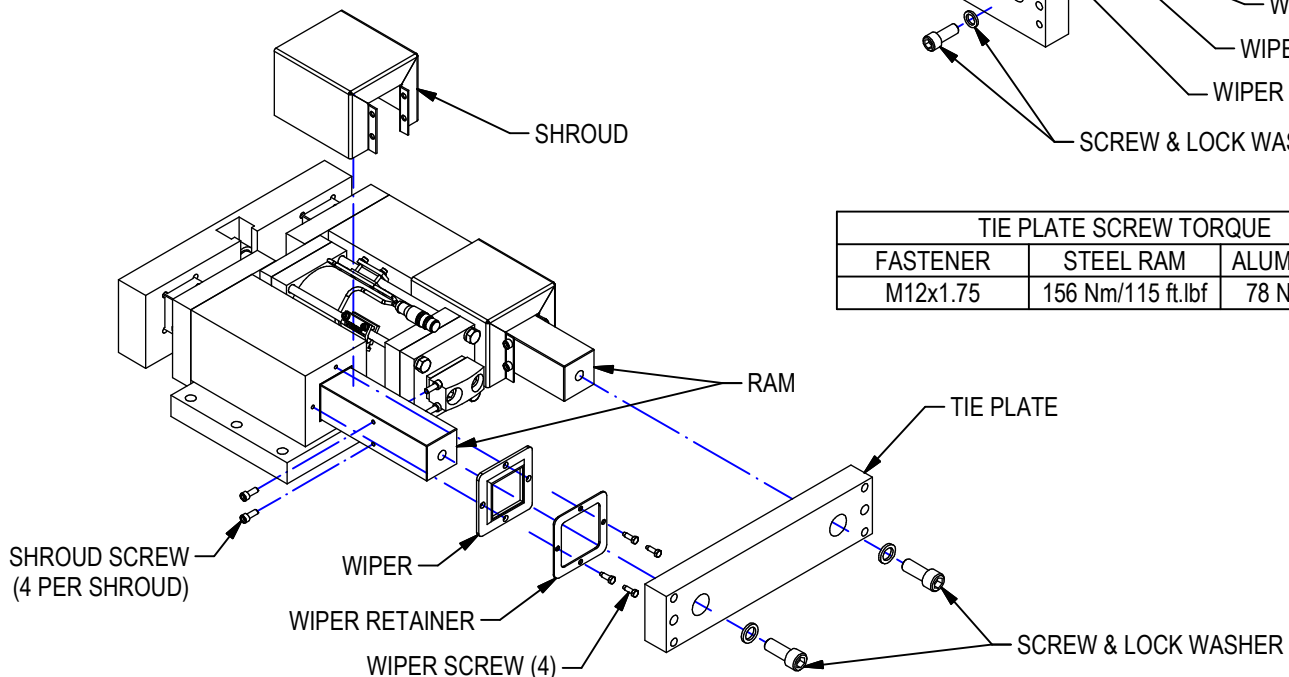
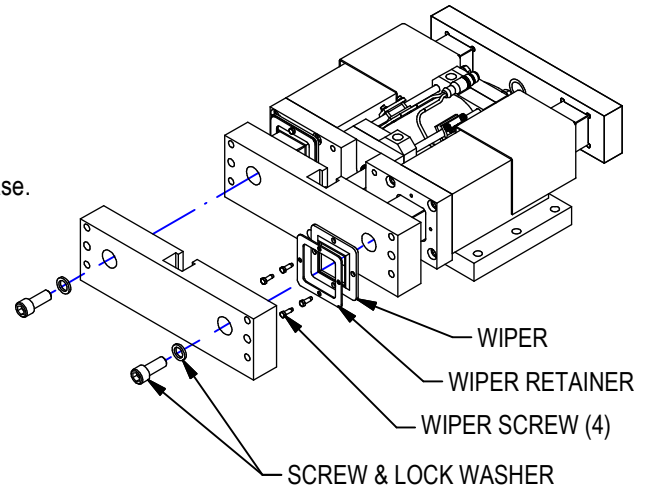

TIE PLATE SCREW TORQUE		
FASTENER	STEEL RAM	ALUMINUM RAM
M12x1.75	156 Nm/115 ft.lbf	78 Nm/58 ft.lbf

CYLINDER / SEAL MAINTENANCE

TO REMOVE CYLINDER:

1. Disconnect air lines from unit. If applicable: disconnect Smart Stop or cylinder switch.
2. Loosen cylinder tie rods enough to dislodge cylinder from tie plate. **KEEP CYLINDER ASSEMBLED**
3. Lift cylinder away from unit, sliding coupler out of slot. Note placement of rigid adapter if present.

TO REPLACE CYLINDER SEALS:

Cylinder seal kit includes: rod wiper, adapter inner & outer seals, piston seal, and 2 tube seals.

1. Remove coupler from cylinder rod (coupler is affixed using removable adhesive).
2. Remove adapter. Replace rod wiper, inner and outer adapter seals.
3. Remove end cap and cylinder tube noting port position of end caps. Clean seal grooves thoroughly. Replace tube seals.
4. Remove piston seal using plastic or brass tool. **NOTE ORIENTATION OF SEAL.** Inspect parts for wear. Clean piston and install new seal.
5. Lightly coat the piston seal and tube I.D. with Acrolube grease.
6. Reassemble cylinder. Make sure tube seals are seated properly in grooves and are not being pinched.
7. Install coupler to cylinder rod using removable adhesive.
8. Return cylinder to unit.
9. Secure tie rods evenly to tie plate. Tighten in an "X" pattern to torque specifications.
10. Check for leaks.
11. Reconnect any necessary switches.

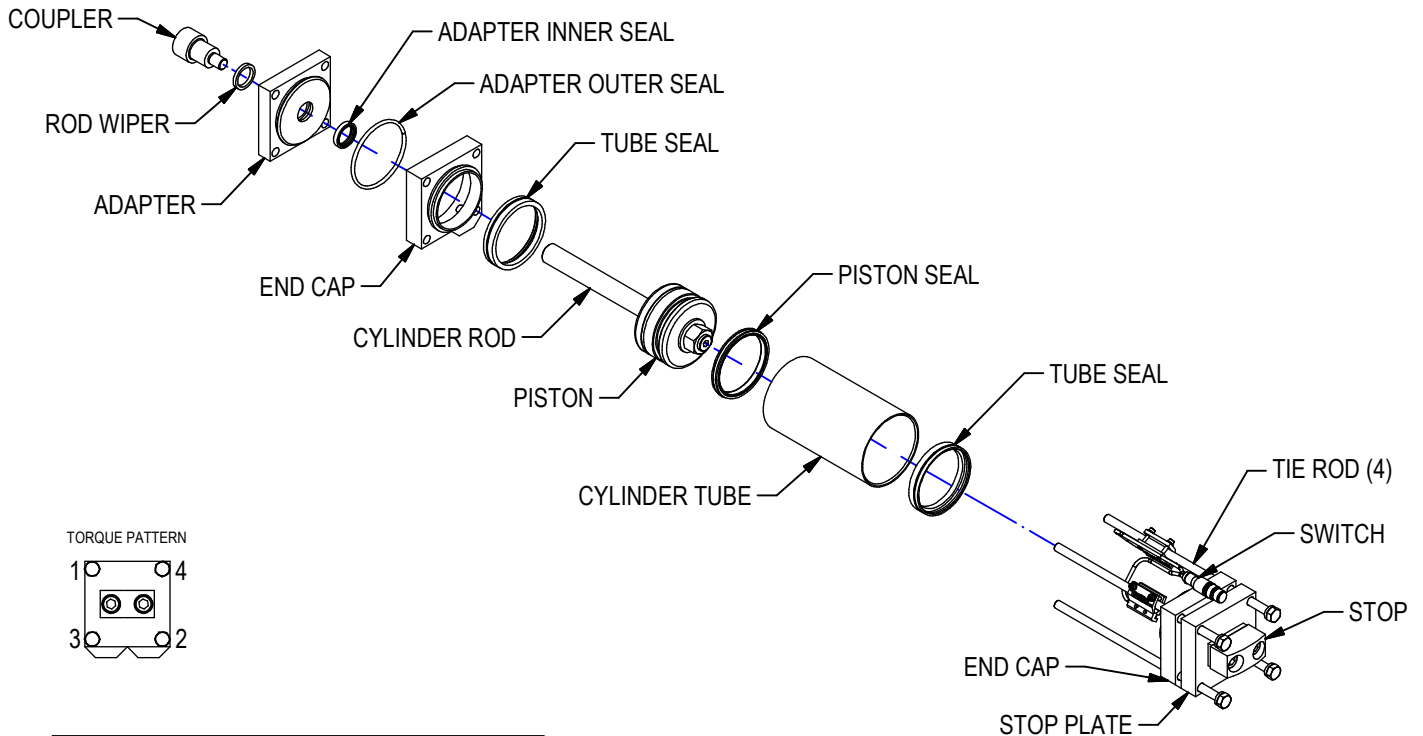
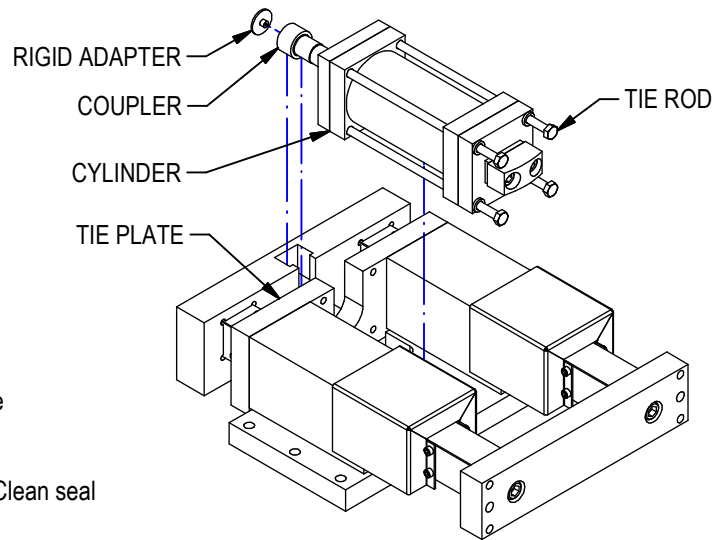

TORQUE PATTERN

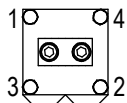

DB4 TIE ROD TORQUE SPECS			
THREAD	FT-LBF	IN-IBF	N-M
5/16-24"	12	144	16.3

REPLACING TIE ROD CYLINDER SWITCH

1. BEFORE REMOVING OLD SWITCH: NOTE SENSOR PLACEMENT!
FOR SWITCHES WITH TWO SENSORS, EACH WILL BE TAGGED
WITH A BAND AROUND THE WIRE INDICATING S1 AND S2 (OR S01
AND S02).
2. TO REMOVE SWITCH, REMOVE BOLTS AND WASHERS FROM
BRACKET. SLIDE BRACKET OUT FROM TIE ROD.
3. SENSOR IS SNAPPED INTO BRACKET. REMOVE.
4. INSTALL NEW SWITCH SENSOR FLUSH INTO BRACKET, BEING
CAREFUL TO MATCH SENSOR CORRECTLY TO LOCATION ON
CYLINDER.
5. LOCATE BRACKET TO CYLINDER, SLIDE ON TO TIE ROD. SECURE
WITH BOLTS & WASHERS.

